

VARASCHIN.IT

Varaschin
OUTDOOR THERAPY

OUTDOOR THERAPY

LANDSCAPES 2021/2022

OUTDOOR THERAPY

LANDSCAPES 2021/2022



Varaschin
OUTDOOR THERAPY



La natura, casa nostra.

Stare all'aria aperta ci riporta a un ideale di vita autentico, ed è il valore che meglio rappresenta la nostra azienda, fatta di storia, passione e specializzazione.

È l'ambizione a cui tendiamo per stabilire un nuovo orizzonte della quotidianità.

Le nostre collezioni sono l'esito di un processo che nasce da un semplice presupposto: il benessere dell'uomo è al centro di tutto.

Nature, Our Home

Staying in the open air gives us a real feeling of what life should be.

It's one of the values that best represents Varaschin, values made of History, Passion and Specialization. It is our primary ambition.

Our collections are the result of a process that has one simple assumption: well-being must be at the center of all things.

emma

design
Monica Armani

Collezione di sedute outdoor con soluzioni di gambe sia in alluminio che iroko massello. Tappezzeria della seduta in tessuto e imbottitura con gomme Dryfeel da esterno. Schienali con telai di alluminio verniciati a polveri e intrecciati a mano. La collezione comprende anche tavolini outdoor con soluzioni di gambe sia alluminio che iroko massello. Top in Hpl o ceramica.

Collection of outdoor seating. Legs available in iroko wood and aluminum. Seat upholstered with fabric and outdoor Dryfeel foam. Back with aluminum frame, hand-woven and powder coated. Collection of outdoor tables with aluminium and iroko wood legs. Hpl and ceramic tops.

MODELLO REGISTRATO

REGISTERED MODEL

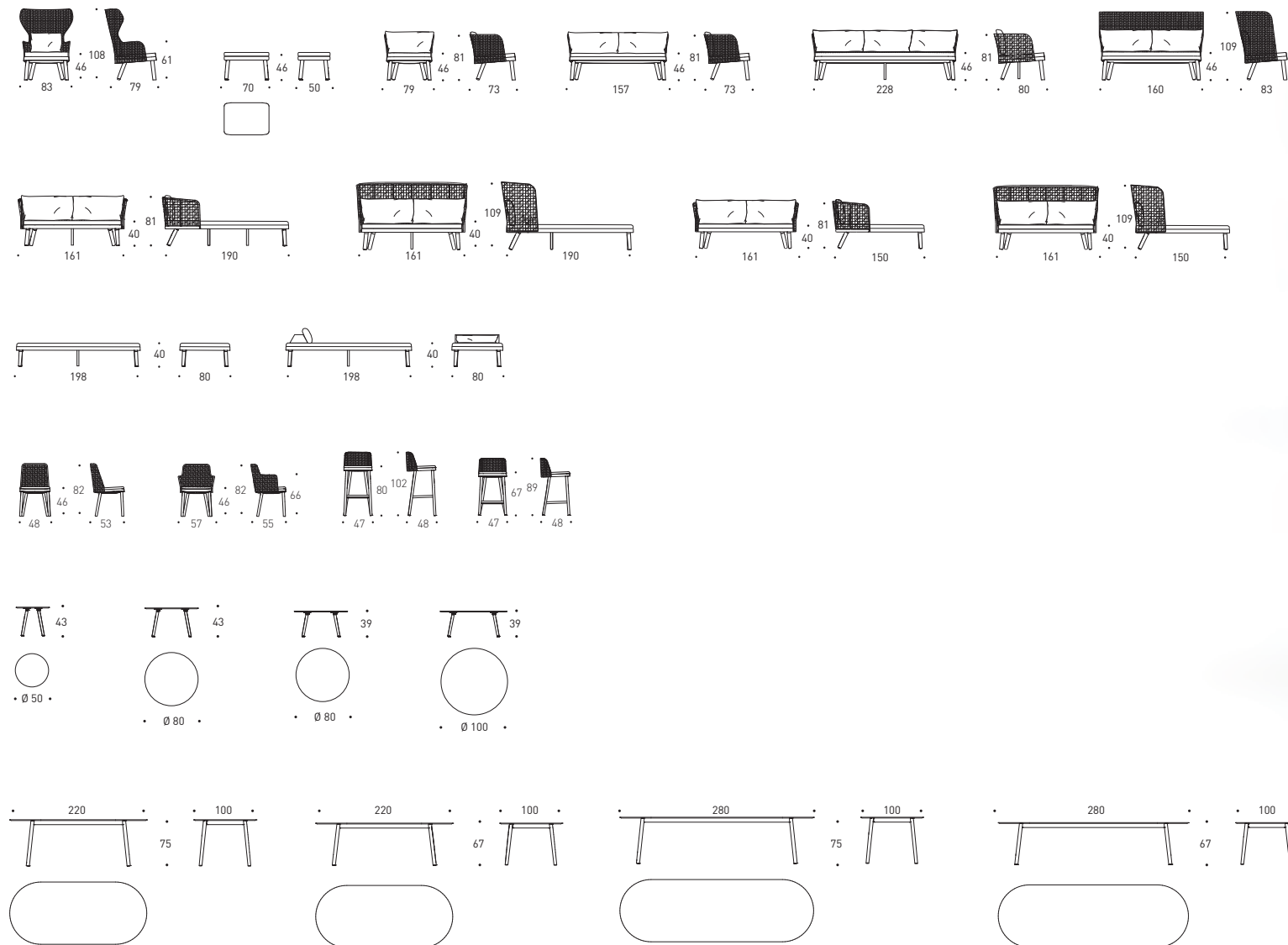

Altezza riferita con top Hpl e ceramica / Height reported with Hpl and ceramic top











OUTDOOR THERAPY IS
bonding time
coziness

Saper godere dei momenti di libertà,
dilatare il tempo affinché gli attimi si cristallizzino in
fotogrammi di intimità.
Amo vivere all'aperto, seguire il ritmo lento delle
giornate liberando la mente dai pensieri
e lasciarmi trasportare dalla natura.

*Knowing how to enjoy moments of freedom, dilating time
so that moments crystallize in frames of intimacy.
I love living outdoors, following the slow rhythm of the
days, freeing my mind from thoughts, and letting myself
be carried away by nature.*





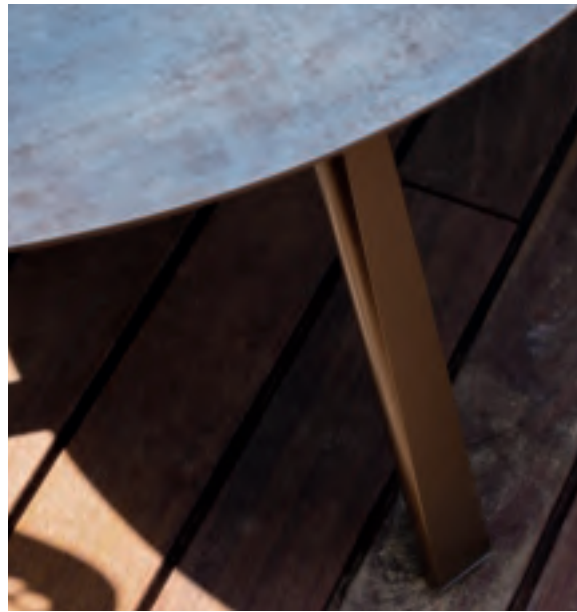



















OUTDOOR THERAPY IS
chill
out



Un attimo speciale, la brezza si è spenta,
la calma del lago diventa una cassa di risonanza pura,
in cui i dettagli prendono vita,
e le nostre azioni quotidiane diventano storia.

*A special moment, the breeze dies down,
the calm of the lake becomes a pure sounding board,
where details come to life,
and our daily actions become history.*







OUTDOOR THERAPY IS
COZY
meeting

Ci sono due cose che desidero trasmettere ai miei figli: le radici e le ali. La libertà di pensiero è come vivere all'aperto, non ci sono confini nei paesaggi come non c'è limite al desiderio di realizzazione.

There are two things that I want to pass on to my children: roots and wings. But freedom of thought is like living outdoors, there are no boundaries in the landscapes as there is no limit to desire of realization.



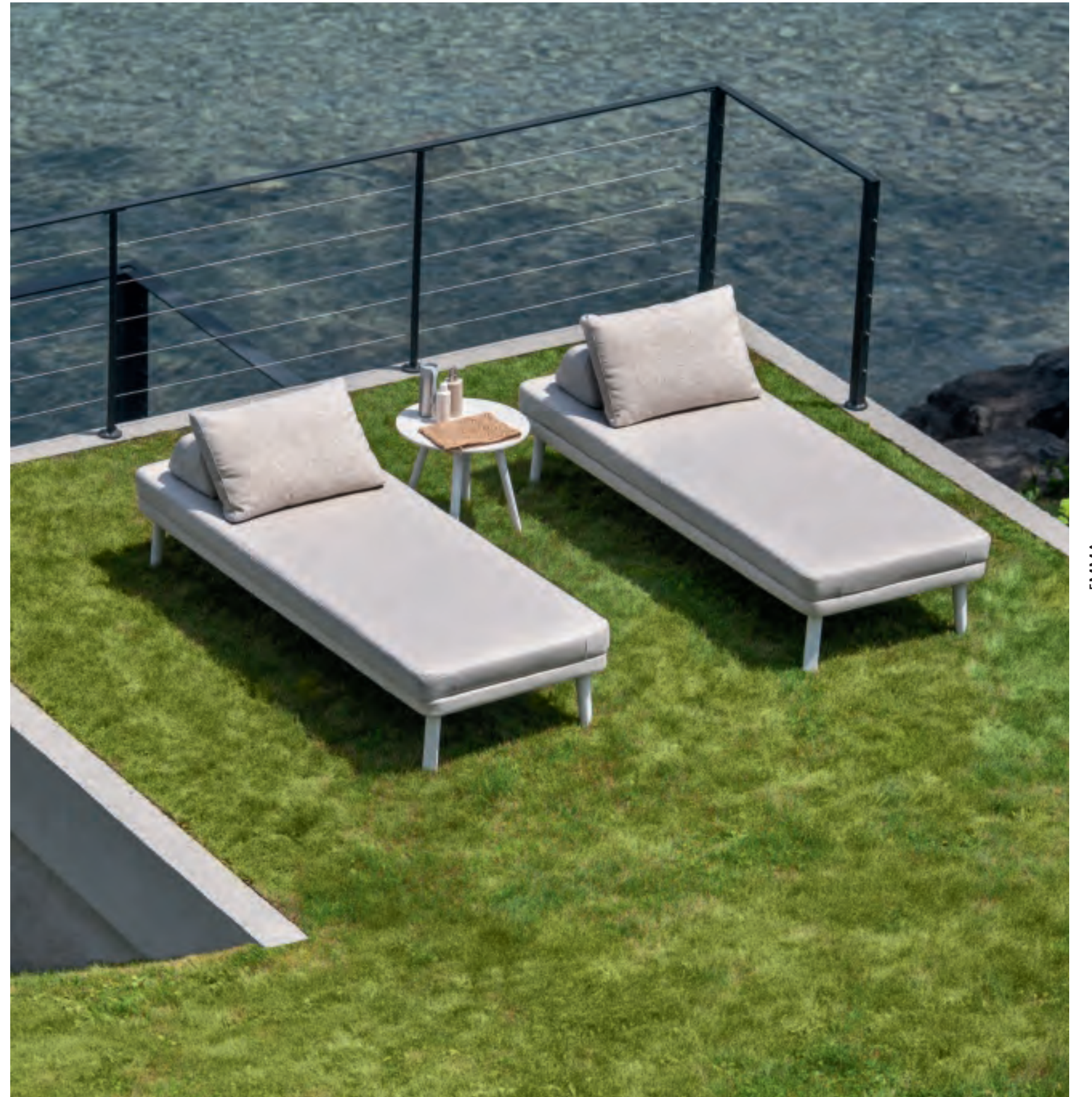



EMMA COLLECTION '21-'22

MMA



OUTDOOR THERAPY IS
togetherness



Una delle cose più belle della giornata è il modo in cui interrompiamo tutto ciò che stiamo facendo per stare insieme. Il pranzo è un intreccio di sorrisi, gesti, ed anche qualche ricordo.

One of the most beautiful things of the day is the way in which we stop what we're doing to be together. Lunch is a mix of smiles, gestures, and also memories.













monica armani

TALKS ABOUT EMMA

Amo definire il mio design come una sorta di processo molecolare. Per la collezione Emma ho creato le mie molecole per il progetto: segno e manifattura dell'intreccio, dettagli raffinati, definizione attenta delle proporzioni, un pizzico di heritage per un progetto/collezione assolutamente lasting.

Muovendomi nel DNA di Emma ho creato i nuovi oggetti per il relax, una raffinata dormeuse e un accogliente daybed.

La collezione Emma, fedele al suo DNA, cresce di anno in anno sempre più protagonista dell'outdoor therapy di Varaschin.

I love to define my design as a sort of molecular process. For the Emma collection, I created the project molecules: weaving design and manufacturing, refined details, careful definition of proportions, a bit of heritage for a lasting project/collecion. Moving into Emma's DNA, I created new objects for relaxation, a refined dormeuse and a cozy daybed. The Emma collection, true to its DNA, grows more and more protagonist every year of Varaschin Outdoor Therapy.

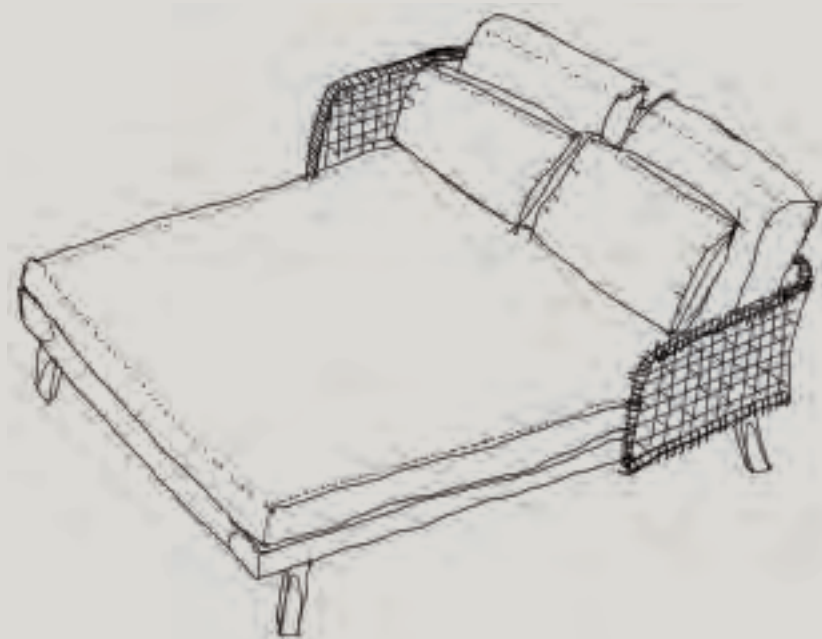

emma cross

design
Monica Armani

Collezione di sedute outdoor caratterizzate da uno schienale intrecciato a mano e realizzato con una speciale fettuccia acrilica imbottita ed un'ampia gamma di varianti cromatiche di abbinamento. Tappezzeria della seduta in tessuto e imbottitura con gomme Dryfeel da esterno. Struttura schienali e gambe in alluminio verniciati a polveri. La collezione comprende anche la possibilità di avere la poltroncina in versione Low.

MODELLO REGISTRATO

Outdoor seating Collection with a hand woven back made of a special acrylic padded tape in a variety of chromatic colours. Seat padding in fabric and Dryfeel Foam for outdoors. Seating structure and legs in powder coated aluminium. Also available a low seating in the collection.

REGISTERED MODEL

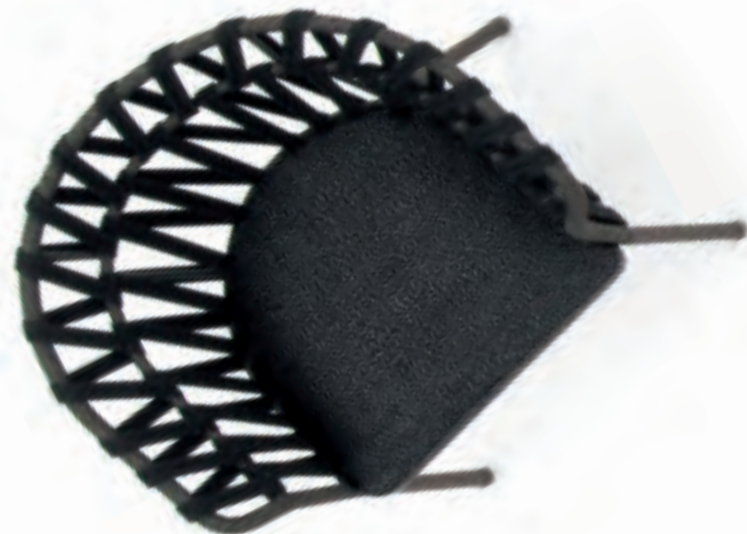
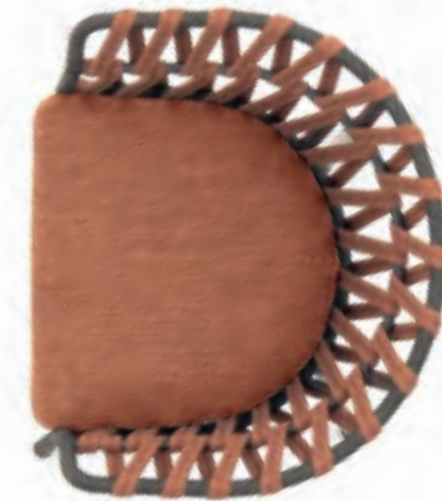







OUTDOOR THERAPY IS
natural
taste



Gli autentici sapori della frutta di stagione,
il gusto rinfrescante di una spremuta colorata.
Amo la genuinità delle cose semplici,
di ciò che posso coltivare e raccogliere.
Riunire poi gli amici intorno ad un tavolo
per condividere la purezza delle nostre ambizioni.

*The authentic flavors of seasonal fruit,
the refreshing taste of a colorful juice.
I love the authenticity of simple things,
of what I can cultivate and harvest.
Then gather friends around a table
to share the purity of our ambitions.*

























ph. Bert Heinzlmeier

monica armani

TALKS ABOUT EMMA CROSS



Per completare il mondo EMMA con il colore è nata EMMA CROSS. Ispirandomi alle corolle dei fiori ho creato una forma che accoglie. Le strutture sono fasciate con una corda nei due toni degli intrecci di EMMA e poi arricchite con un intreccio deciso ma allo stesso tempo organico. Questo intreccio è realizzato in cinque colori, due tono su tono, un rosso che ricorda le terre, un verde ispirato alle foreste e un azzurro cielo polveroso. EMMA una collezione sempre più completa per ogni situazione outdoor.

To complete the EMMA world with colour EMMA CROSS was conceived.

Inspired by the corollas of flowers I created a shape that really welcomes them.

A woven structure with EMMA cords in the two standard tones, enriched with a second stronger but still organic weave. 5 different colours, 2 tone on tone, a red that reminds me of a clay soil, green of the forest and a light dusty sky blue.

Emma: a collection that is perfect for any outdoor scenario.



EMMA CROSS

emma

SUNSCREEN

design
Monica Armani

Parasole orientabile con struttura in alluminio verniciato a polveri.
Rivestimenti in tela Batyline e Vartex abbinati ai 6 colori della struttura.

MODELLO REGISTRATO

*Adjustable Sunscreen with aluminium powder coated structure.
Materials in Batyline and Vartex matching the 6 colors of the structures.*

REGISTERED MODEL

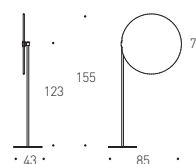









tibidabo

design
Calvi Brambilla

Collezione intrecciata a mano in fibra sintetica con struttura in alluminio verniciato a polveri. Cuscini con imbottitura gomme Dryfeel da esterno.

MODELLO REGISTRATO

Collection in powder coated aluminium frame and hand woven man-made fibre. Cushions in Dryfeel outdoor foam.

REGISTERED MODEL

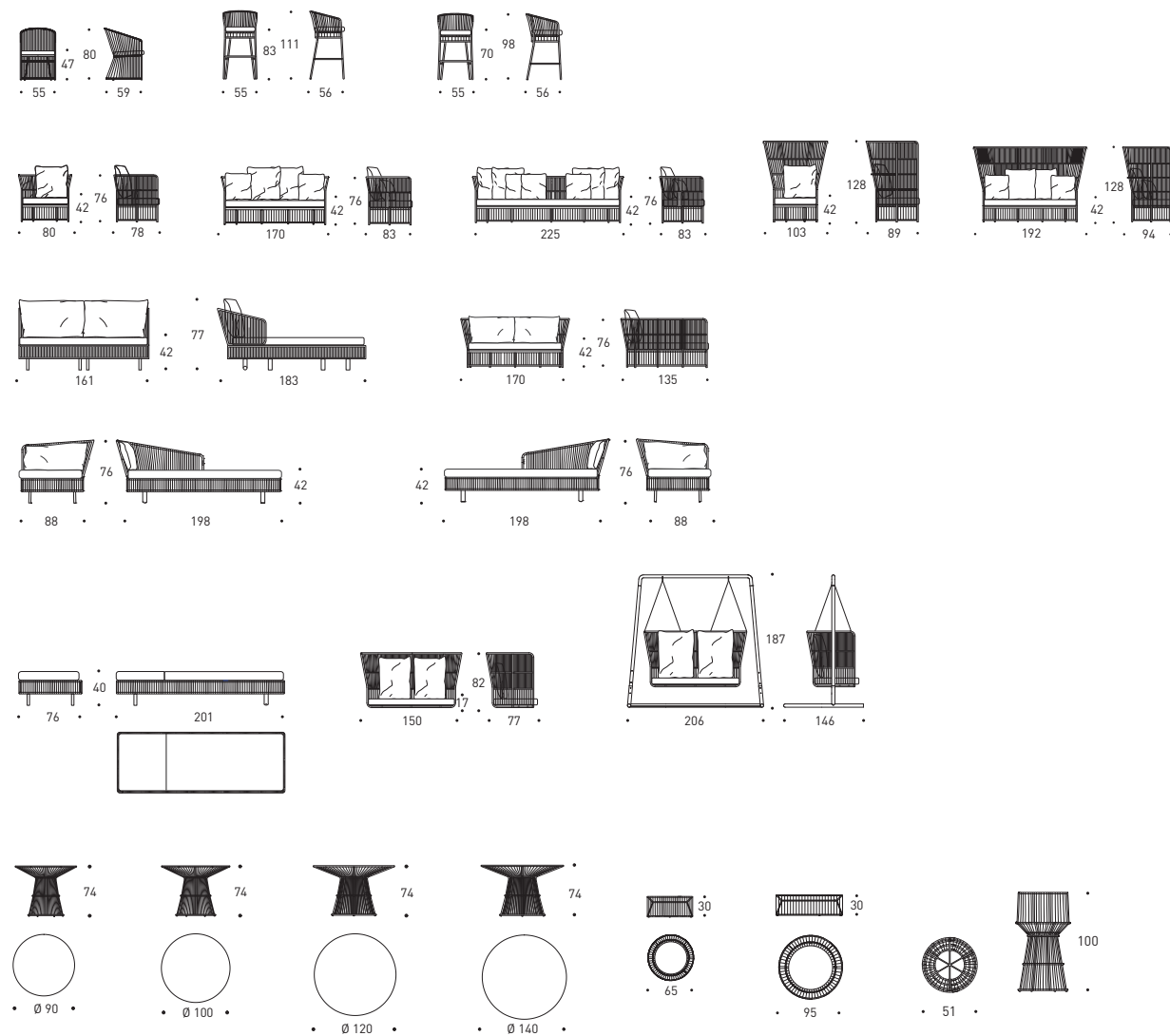

Altezza riferita con top Hpl e ceramica / Height reported with Hpl and ceramic top





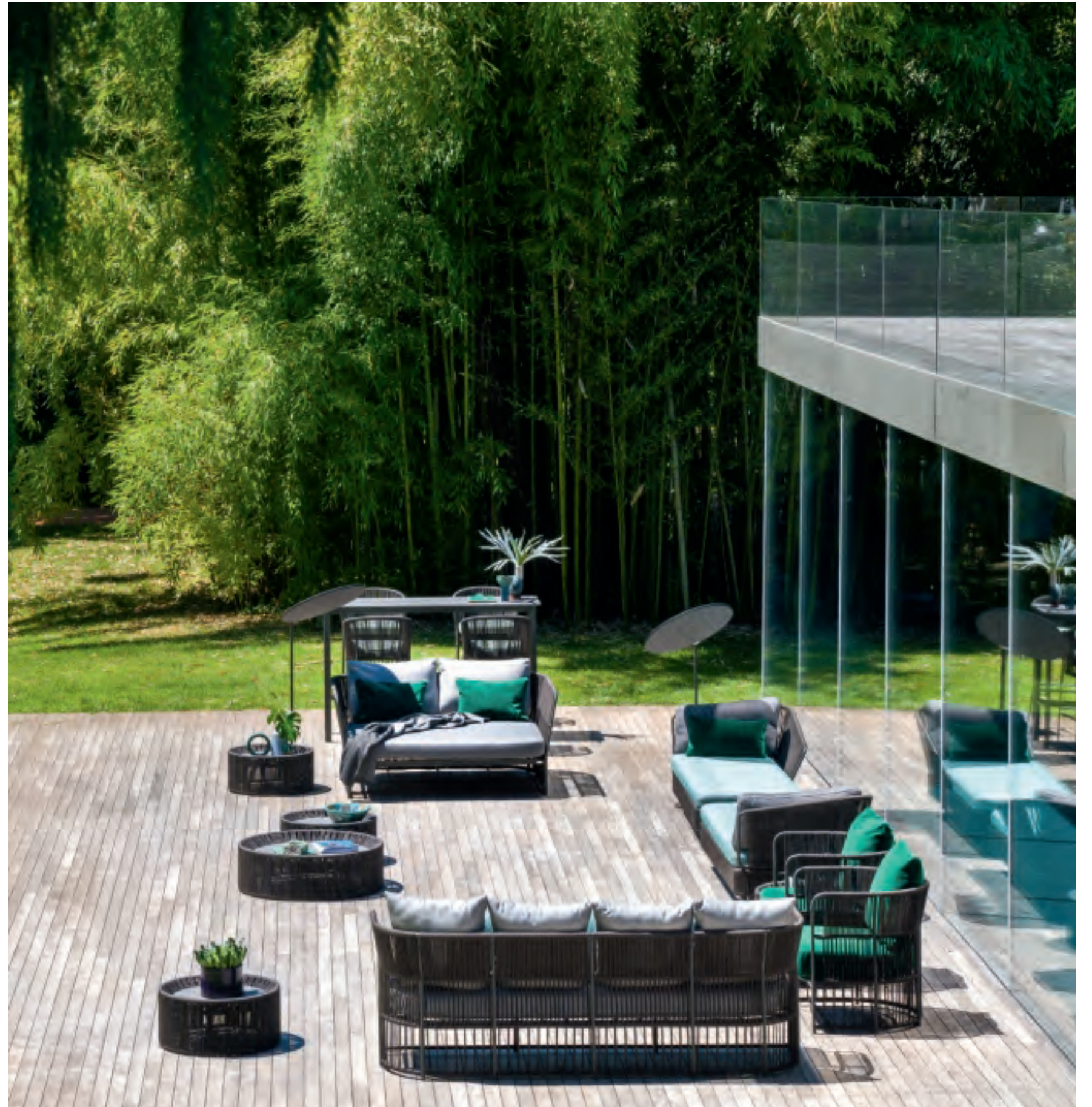
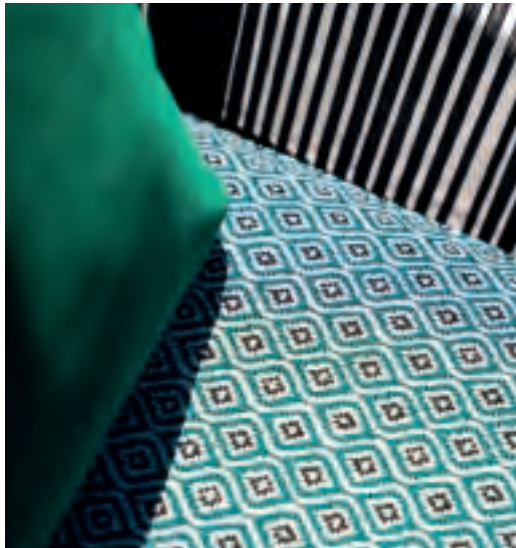









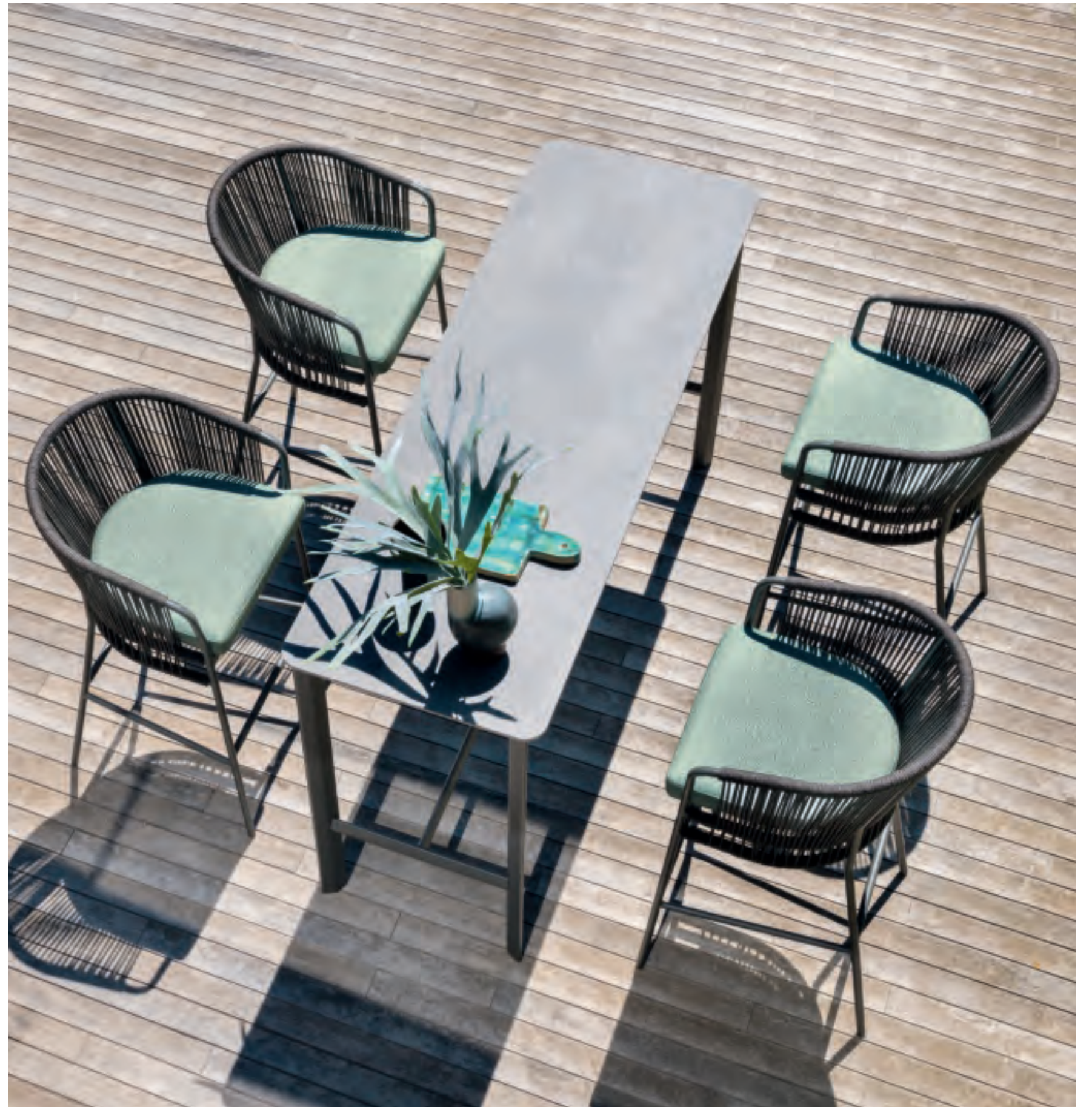

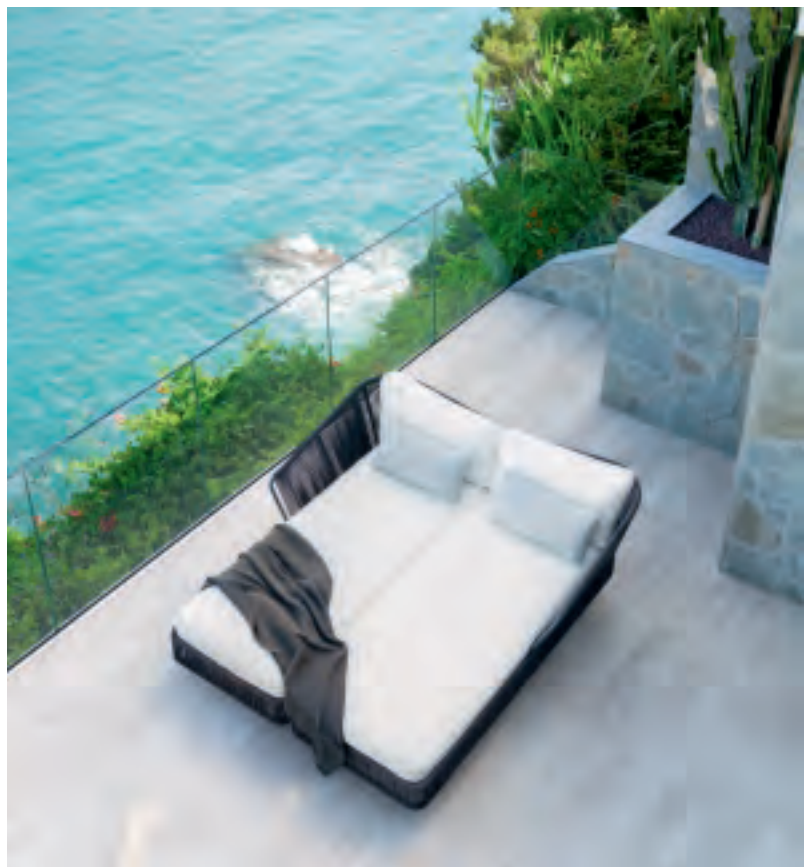



















OUTDOOR THERAPY IS
play time



L'aria aperta suggerisce una creatività
che mantiene attiva la mente
ed è il sano fenomeno sociale
che non finge nulla.
Forse la vita è l'unico gioco
in cui il gioco stesso
è impararne le regole.

*Open air suggests creativity
which keeps the mind active
and it is the healthy social phenomenon
that does not pretend anything.
Maybe life is the only game
where the game itself is learning the rules.*











L'ispirazione nasce da un libro per bambini di Bruno Munari "Disegnare un albero", dove partendo da una schematizzazione grafica della crescita vegetale, Munari insegna a disegnare vari tipi di alberi: una semplice linea che rappresenta il tronco si moltiplica in maniera regolare e proporzionale fino a formare la chioma. Abbiamo pensato di portare questo schema di crescita su un foglio bianco e poi di curvare il foglio stesso attorno ai cuscini. Il risultato è un binomio di eleganza essenziale ed estrema semplicità associato a colorazioni bianco e nero che ne sottolineano l'estetica fortemente grafica.

calvi brambilla

TALKS ABOUT TIBIDABO



The inspiration comes from a children's book by Bruno Munari, "Draw a tree". In the book Munari teaches how to draw various types of trees starting from a plant growth graphic schematization. A simple line represents the trunk and multiplies on a regular and proportional basis until it forms the foliage. We had the intuition to bring this growth pattern onto a white sheet and then bend the sheet around the pillows. The result is a combination of essential elegance and extreme simplicity associated with black and white colorings which emphasize the strong graphic aesthetics.



belt

design
Daniele Lo Scalzo Moscheri

Collezione imbottita. Versione outdoor: struttura portante in legno massello di okumè e imbottitura con gomme Dryfeel da esterni.
Versione indoor: struttura portante in legno massello di abete e imbottitura in gomma da interno.
Disponibile in versione monotessuto o bitessuto con diversi colori.

Padded modular sofa.
Outdoor version: structure in solid Okoumè wood and outdoor Dryfeel foam.
Indoor version: fir wood and indoor foam.
Both available in mono or bi-fabric versions in different colours.

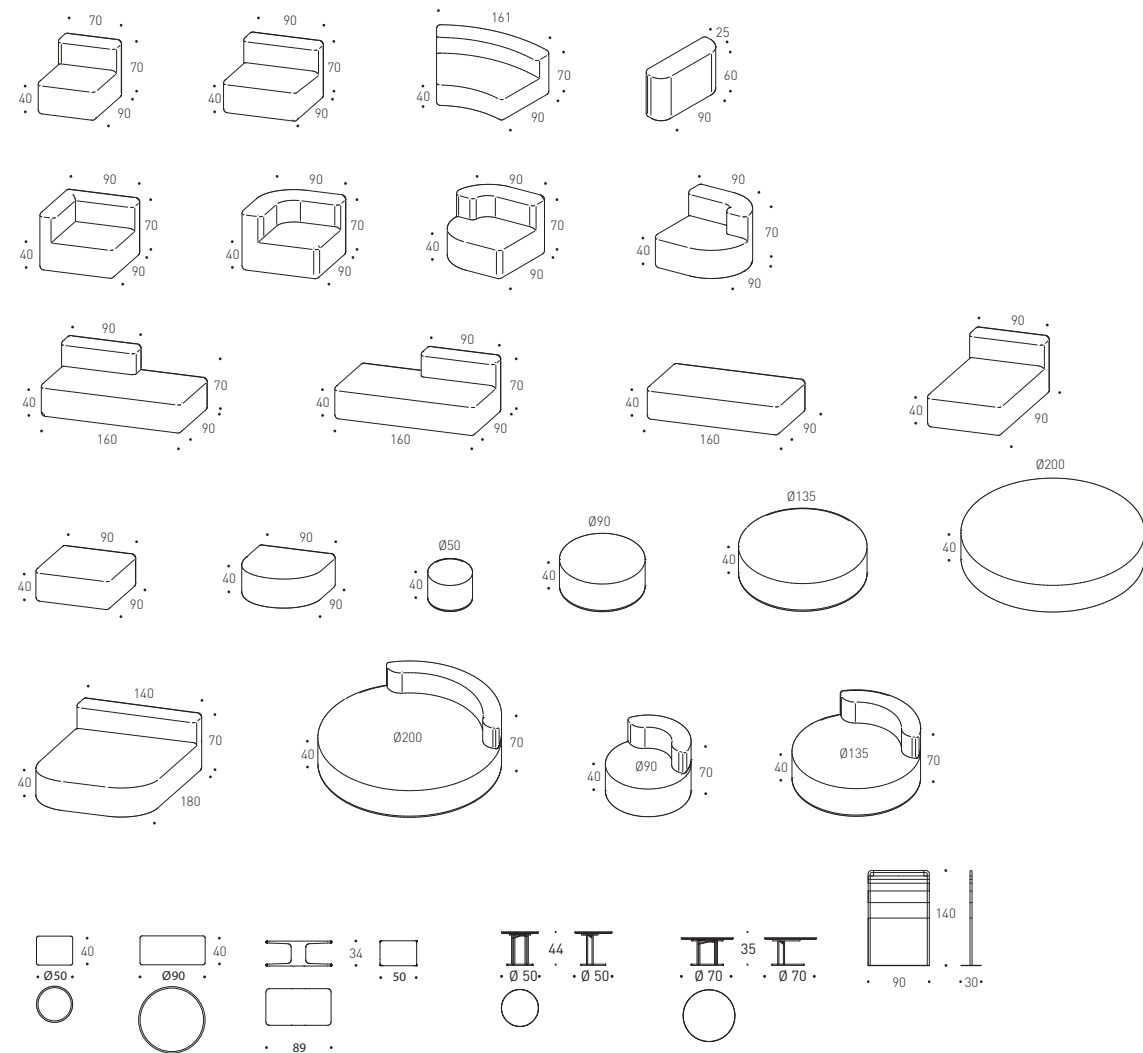



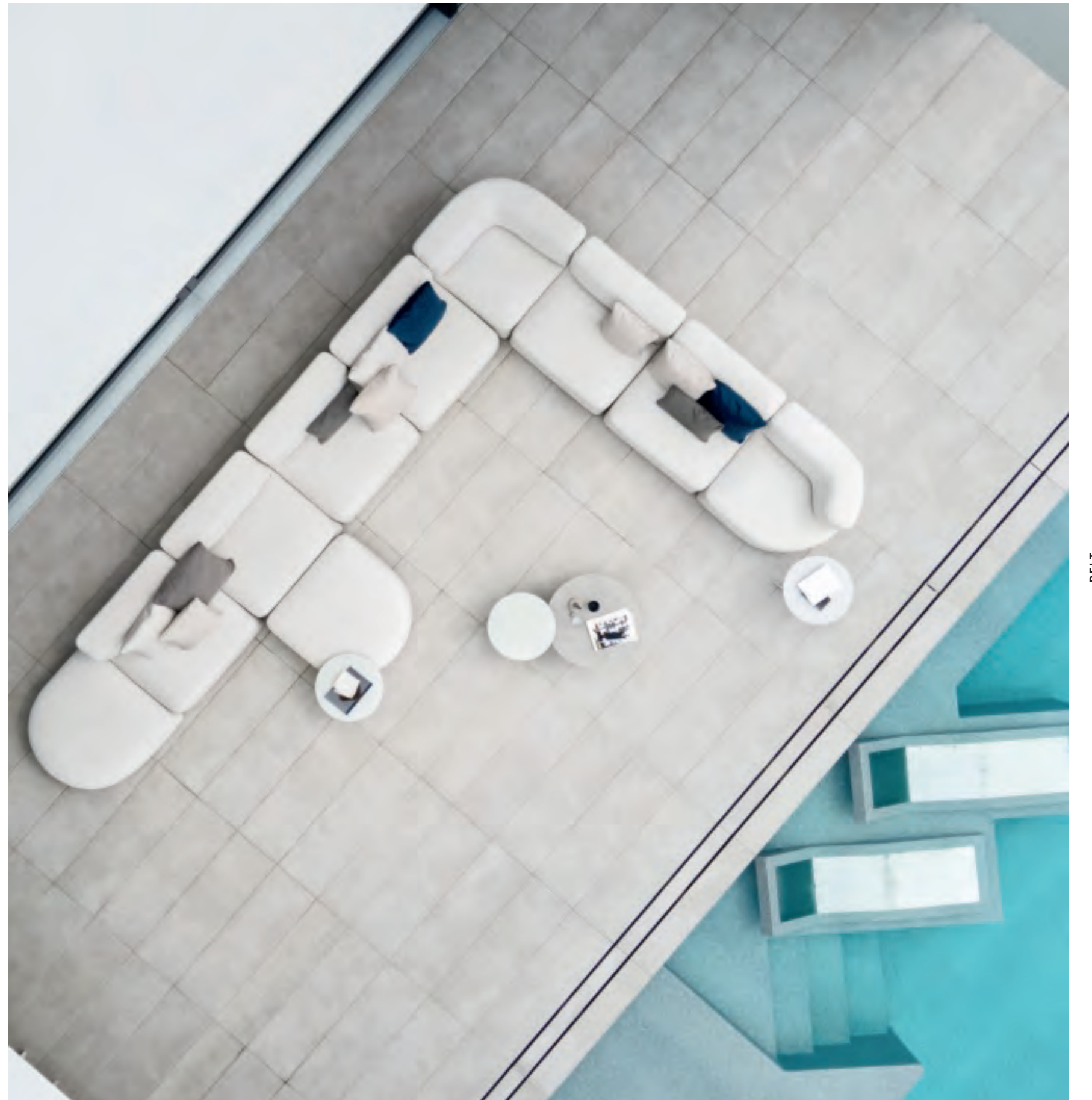



LANDSCAPES '21_'22

OUTDOOR THERAPY IS

weaving stories



Le nostre storie si intrecciano, e si arricchiscono di nuove esperienze. Insieme condividiamo un altro obiettivo, la convivialità di un divano ci permette di essere più autentici e veri, è come se l' outdoor fosse un catalizzatore di emozioni in cui la condivisione dei pensieri diventano attimi magici ed unici per storie sempre diverse.

Our stories are entwined and enriched with new experiences. The conviviality of a sofa allows us to be more authentic and real. The outdoors becomes a catalyst of emotions where thoughts become magical moments, unique and different tales.







OUTDOOR THERAPY IS
yoga breath

Non ho bisogno di altro. Lo yoga è linfa vitale, apre la porta della mia mente, e la mia intimità trova il suo respiro. Il silenzio, la natura, i colori, i suoni sono tutti elementi originali e autentici e rappresentano tutto ciò che serve per ritrovare me stessa. Approfittare dell'aria aperta è una opportunità che va sfruttata per ritrovare il contatto con ciò che davvero conta. Se stessi.

I don't need anything else. Yoga is the lifeblood, it opens the door of my mind, and my intimacy finds its breath.

Silence, nature, colors, sounds are all original and authentic elements and represent all that is needed to find myself.

Taking advantage of the outdoors is an opportunity that must be used to find contact with what really matters. Yourself.

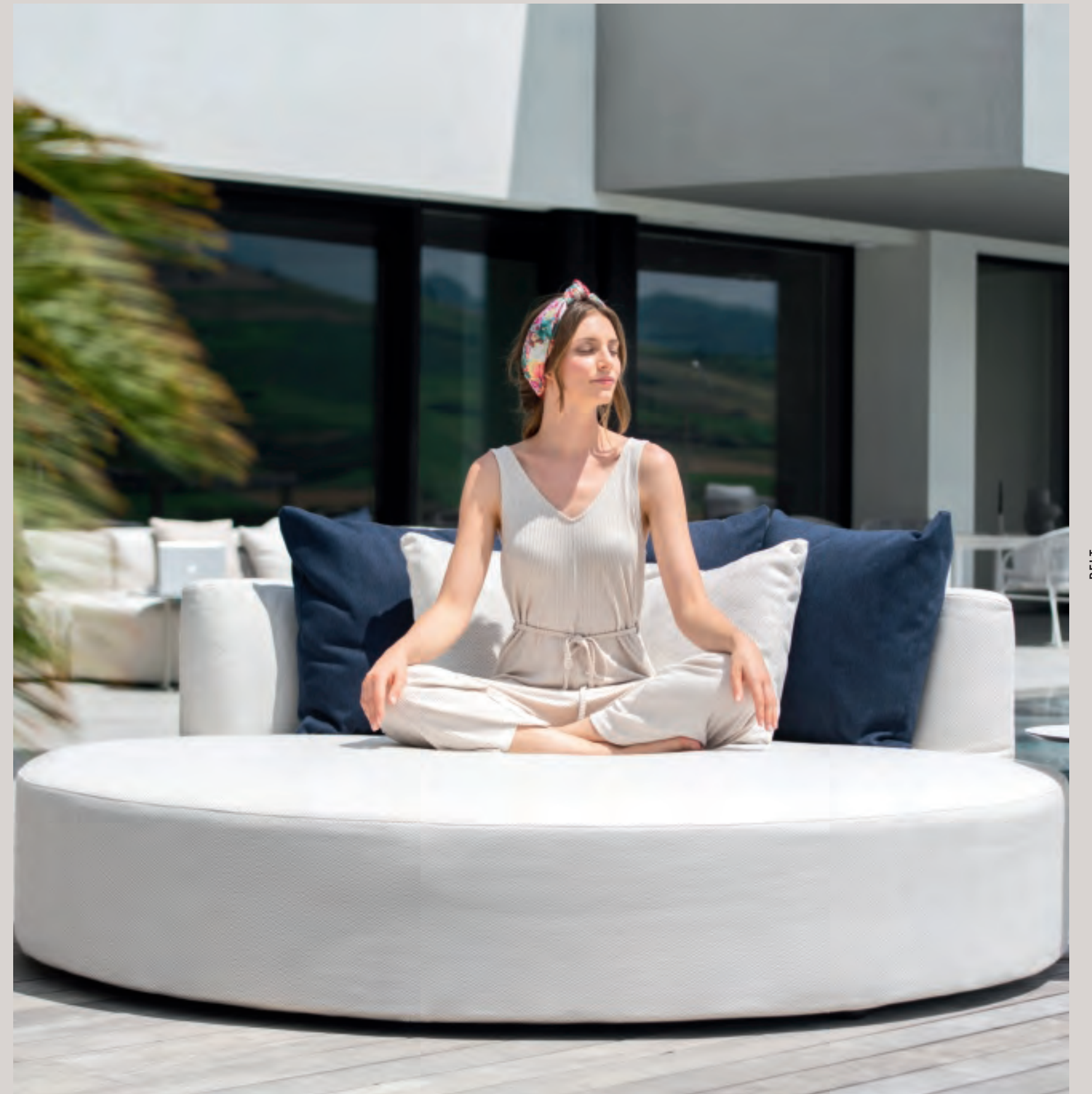







OUTDOOR THERAPY IS

sharing passion

LANDSCAPES '21_'22



La libertà è una virtù,
la condivisione una scelta.
Ci piace vivere insieme le nostre passioni.
La corsa, il rumore dei passi sul terreno,
il respiro che trova il suo ritmo. il corpo si
sincronizza con l'esterno.
Per noi l'attività all'aria aperta è una valvola
di sfogo, ed una ricarica di energia
per corpo e spirito.

*Freedom is a virtue, sharing a choice.
We like to live our passions together.
The race, the sound of footsteps on the
ground, the breath that finds its rhythm.
The body synchronizes with the outside.
For us, outdoor activities are a relief valve,
and a recharge of energy for body and
spirit.*



BELT



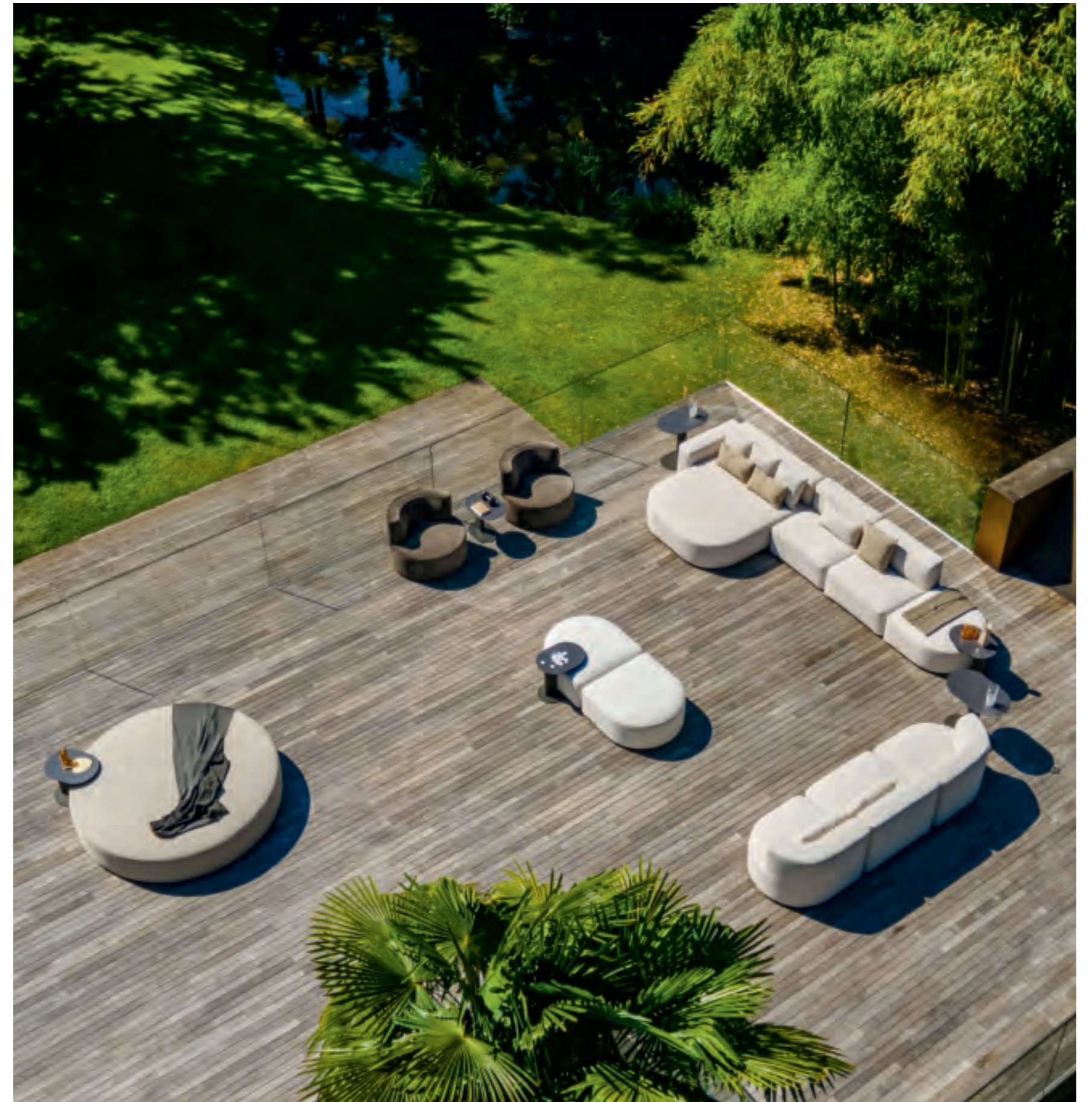













soluzioni d'arredo

MULTIPLE SOLUTIONS

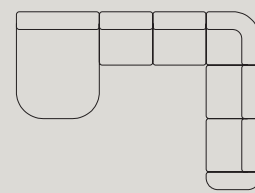

/01

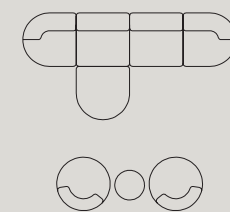

/02

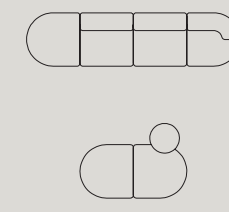

/03

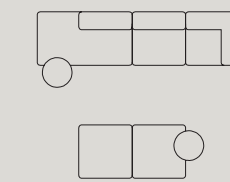

/04

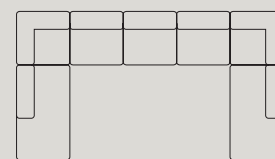

/05

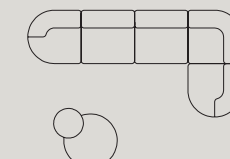

/06

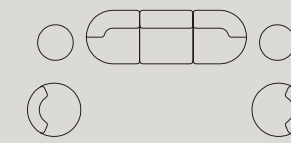

/07

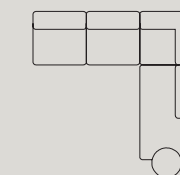

/08









soluzioni d'arredo
MULTIPLE SOLUTIONS

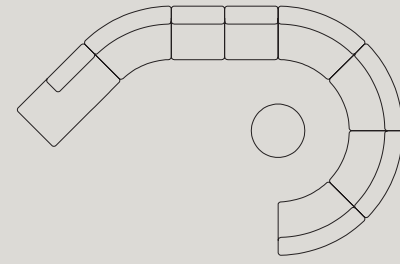

/01

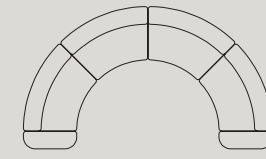

/02

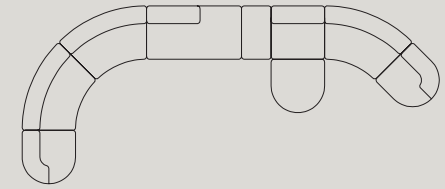

/03

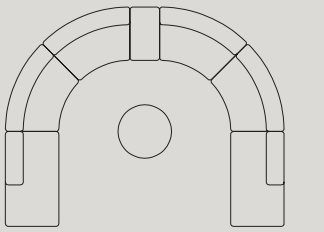

/04

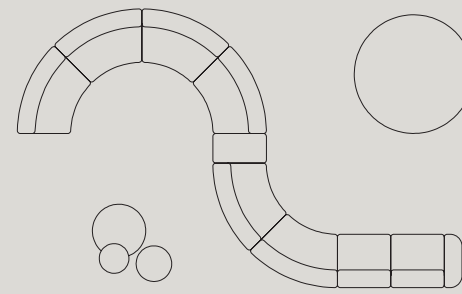

/05

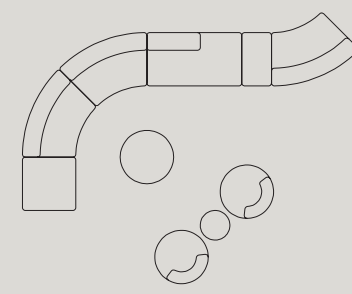

/06

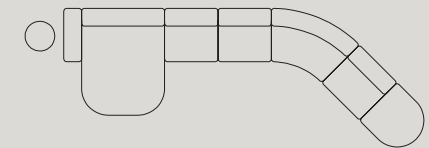

/07

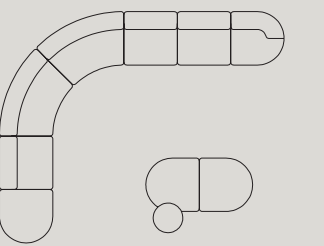

/08

daniele lo scalzo moscheri

TALKS ABOUT BELT



Quando nasce un progetto identifichi una partenza ed un obiettivo.

Belt rappresenta un orizzonte infinito di soluzioni che anno dopo anno implementano la sua capacità di espressione per la estrema componibilità. La creatività in questo caso alimenta nuove configurazioni e nuovi moduli pensati per un living informale, unisex e soprattutto progettabile. Belt è un divano totalmente tessile, che veste tutta la nostra collezione e suggerisce ogni volta il quadro perfetto con i colori tipici di un paesaggio.

When a project is born, you identify a start and a goal.

Belt represents an infinite horizon of solutions that year after year increase its expression capacity for its extreme modularity.

In this case creativity feeds new configurations and new modules designed for an informal, unisex and above all designable living.

Belt is a totally textile sofa, which covers our entire collection and suggests the perfect picture every time with the typical colors of a landscape.

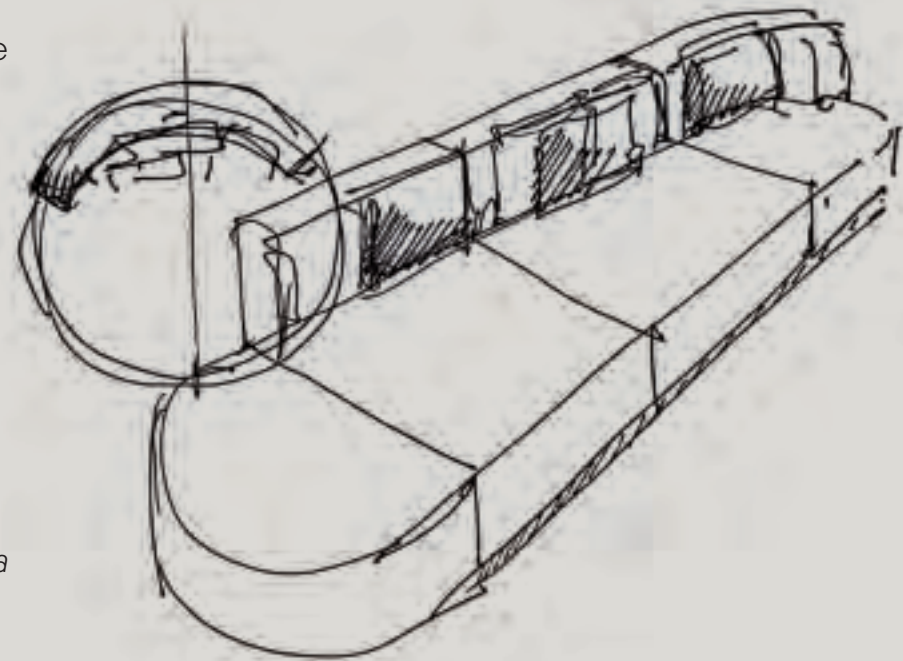

summer set

design
Christophe Pillet

Collezione con struttura in tondino di acciaio con trattamento cataforesi verniciato a polveri.
Basi tavoli in alluminio verniciato a polveri e complete di piedini regolabili.

Collection in cataphoresis treated, powder coated steel rods and cataphoresis treatment.
Table bases in powder coated aluminum and complete with adjustable feet.

MODELLO REGISTRATO

REGISTERED MODEL

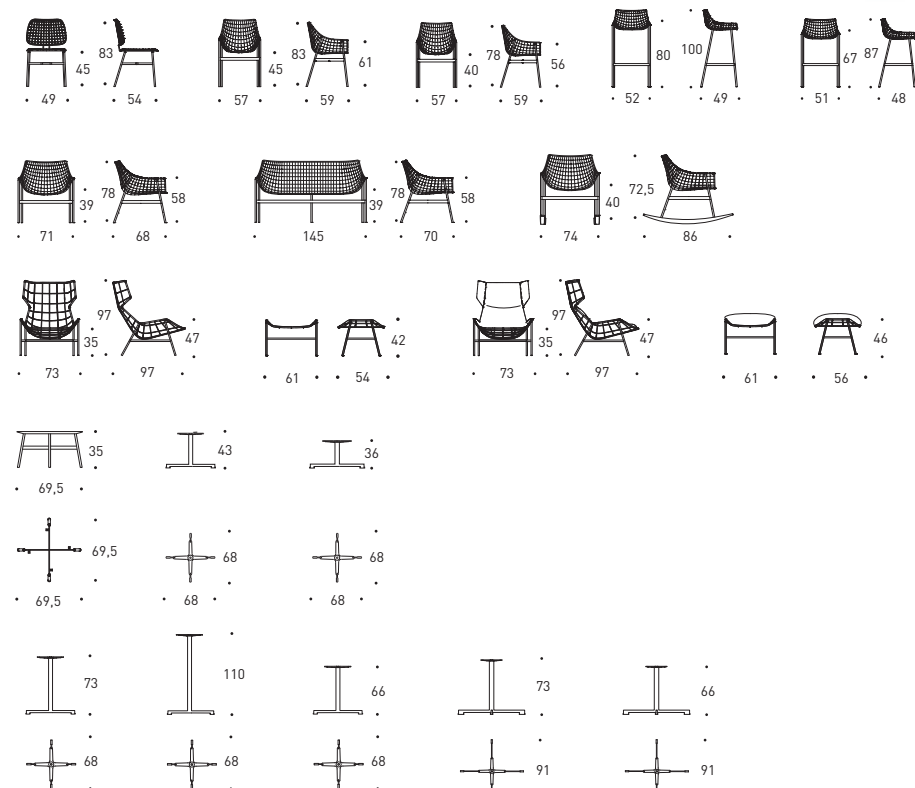

Altezza riferita senza top / Height reported without top















low seats

SUMMER SET



LANDSCAPES '21_'22



SUMMER SET

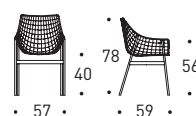

Low dining armchair

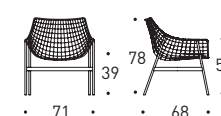

Lounge armchair













christophe pillet

TALKS ABOUT SUMMER SET



La Summer Set Lounge & Ottoman è una declinazione più confortevole e generosa della collezione Summer Set, che recupera le caratteristiche della struttura a maglie con cuscino, ottenendo una moderna espressione più lussuosa e senza tempo. Nel corso del suo sviluppo, la collezione si è arricchita con una serie di nuovi elementi: sgabelli, poltrone, sedie a dondolo, divano, sviluppando le sue forti caratteristiche e identità.

The Summer Set Lounge & Ottoman is a more comfortable and more generous declension of the collection Summer Set, which takes back the characteristics of the mesh structure with cushion, within a modern expression more luxurious and timeless. By the time, the collection was extended with a number of new items, stools, armchairs, rocking chairs, sofa, developing its strong and characteristic identity.

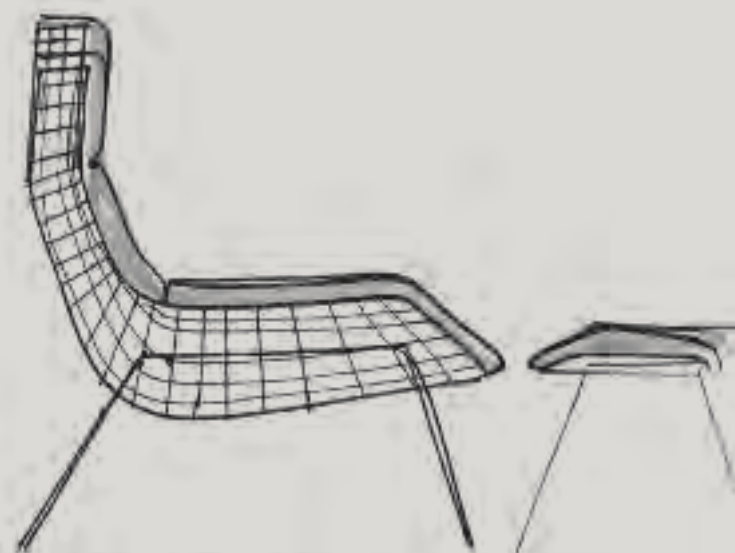

VANAS OMA
FAC. GEMEC



cricket

design
Anki Gneib

Collezione intrecciata a mano in fibra sintetica
con intelaiatura in alluminio verniciato.

MODELLO REGISTRATO

Collection with powder coated aluminium frame
and hand woven man-made fibre.

REGISTERED MODEL



LANDSCAPES '21_'22

CRICKET

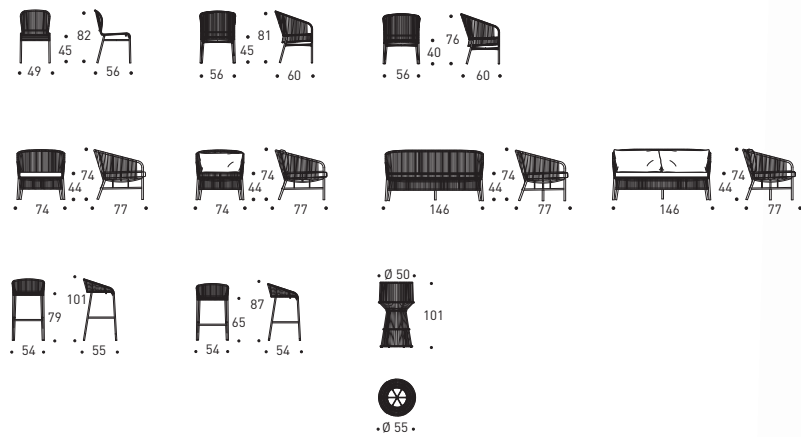



LANDSCAPES 21-22

CRICKET







OUTDOOR THERAPY IS
travel experience

LANDSCAPES '21_'22



Sono un viaggiatore per natura, e la natura è il centro del mio interesse ed è diventata oggetto del mio lavoro. Viaggio per arricchirmi di tutto quello che il nostro pianeta ci offre, da qui parte la consapevolezza che dobbiamo proteggerlo. La fotocamera è il mio punto di osservazione, ma anche la mia dichiarazione di responsabilità.

I am a traveler by nature, and nature is the center of my interest and has become object of my work. I travel to enrich myself with all that our planet offers us, hence the awareness that we must protect it. The camera is my point of view, but also my declaration of responsibility.



CRICKET

low
DINING



LANDSCAPES '21_'22

CRICKET



















anki gneib

TALKS ABOUT CRICKET



LANDSCAPES '21_'22

La mia idea con la collezione Cricket era quella di creare una reinterpretazione moderna della classica sedia da giardino: invitante e amichevole con un fascino senza tempo. Una collezione di sedute che si combina a diversi scenari, indoor e outdoor.

Il nome Cricket rievoca sia il gioco che con mazza e palla si pratica all'aria aperta, sia l'insetto dal corpo pieno e le gambe snelle, che risuona con il suo canto nelle caldi notti d'estate.

My intention with the Cricket collection was to make a contemporary reinterpretation of the classic garden chair. Inviting and friendly with a timeless charm.

A collection of seating that fits into many settings, indoors and outdoors.

The name Cricket associates both with the outdoor bat and ball game played on a green field. Or with the appearance of the insect Cricket, with its full body and slender legs, but also with their chirping song on a hot summer night.



CRIC

babylon

design
Giopato & Coombes

Collezione di sedute composta da divano, poltrona, pouf, tavolini bassi e lettini in fibra sintetica intrecciata a mano con struttura in alluminio verniciato.

MODELLO REGISTRATO

Seating collection comprising sofa, armchair, pouf, low coffee tables and sunbeds with aluminium frame and hand woven man-made fibre.

REGISTERED MODEL



LANDSCAPES '21_'22

BABYLON

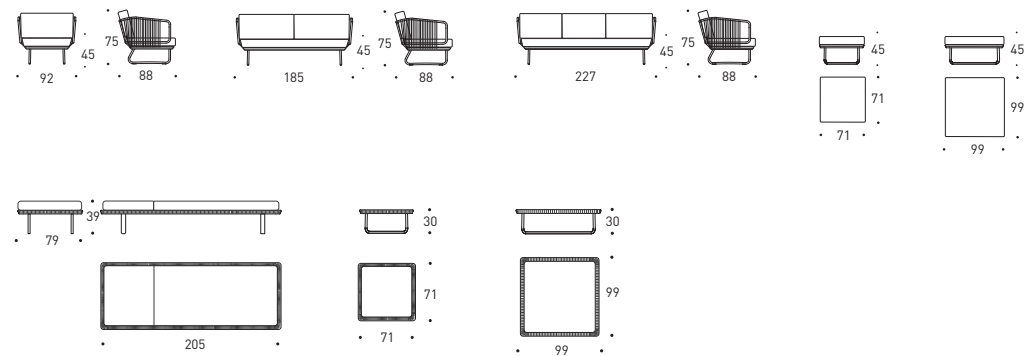



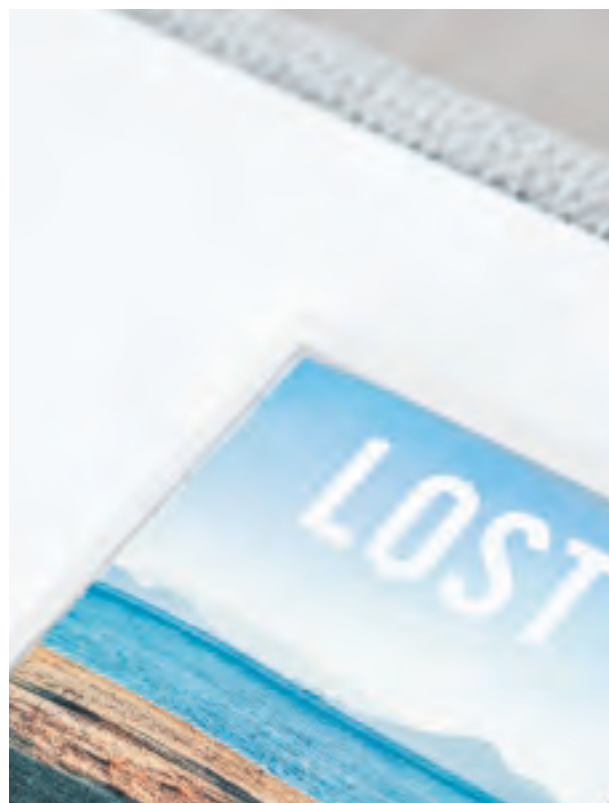





OUTDOOR THERAPY IS
collecting
memories

LANDSCAPES '21_'22



Una istantanea ferma il tempo, aggiungendo al nostro album un altro ricordo, un nuovo viaggio, una ulteriore esperienza vissuta insieme. La fotografia conserva momenti straordinari. Le nostre passioni si intrecciano, come in una fitta trama, e riusciamo sempre a trovare un equilibrio.

A snapshot stops time, adding to our album another memory, a new journey, a further experience lived together. Photography holds extraordinary moments. Our passions are intertwined, as in a dense weave, and we always manage to find a balance.



BABYLON







giopato & coombes

TALKS ABOUT BABYLON

Quando ci siamo posti di fronte a questo progetto in realtà avevamo una chiara idea, non tanto formale, quanto della sua funzione. Christopher ed io amiamo passare le notti estive ad osservare le stelle, un pò forse perchè ci ricorda le notti in barca a vela. Il brief che ci siamo posti è stato quello di un divano per osservare il cielo nelle notti stellate.

When we approached this project we actually had a clear idea, not about the shape but about its function. Christopher and I love spending summer nights looking at the stars, maybe because this reminds us about sailing nights. The brief from which we started was that of a sofa to observe the sky during starry nights.

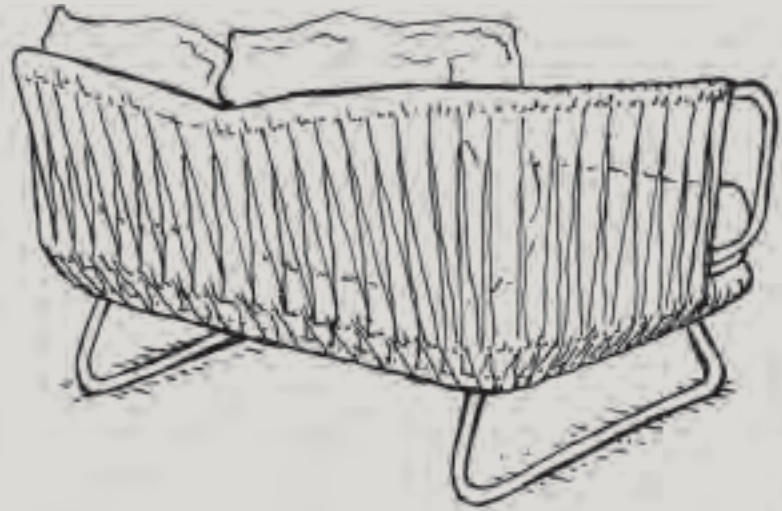

system star

design
Daniele Lo Scalzo Moscheri

Collezione di tavoli fissi con struttura in alluminio verniciato a polveri e top quadrati, rotondi, rettangolari ed ellittici in HPL o ceramica.
MODELLO REGISTRATO

Fixed tables with powder coated aluminium structure and square, round, rectangular or elliptic tops, available in HPL or ceramic.
REGISTERED MODEL

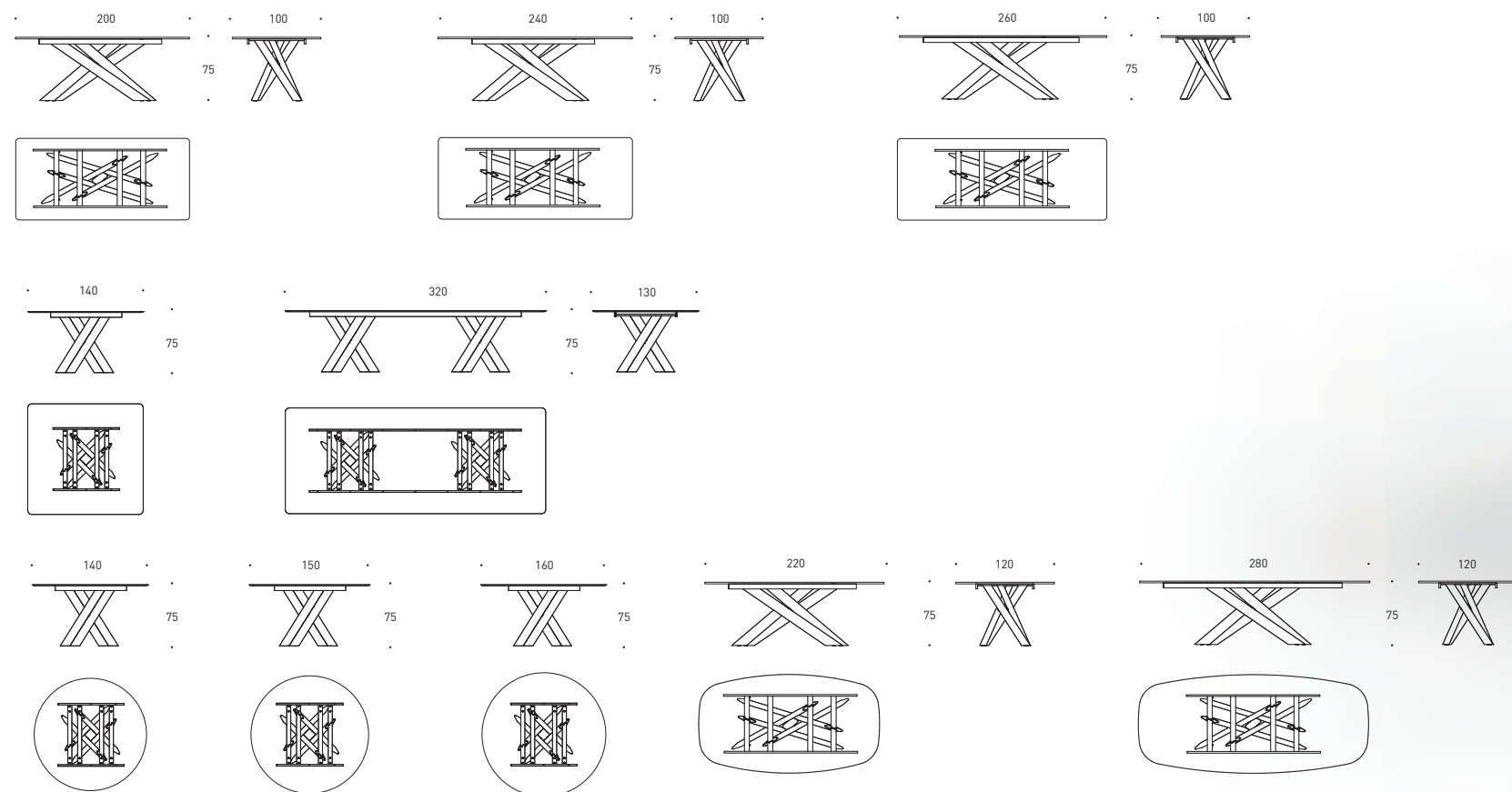

Altezza riferita con top Hpl e ceramica / Height reported with Hpl and ceramic top.

















system

design
Daniele Lo Scalzo Moscheri

Collezione di tavoli, tavolini e panche con struttura in alluminio verniciato a polveri con top in Hpl o Ceramica.

Panca disponibile anche imbottita o con seduta in teak di piantagione certificata.

MODELLO REGISTRATO

Collection of tables, coffee tables and benches with aluminum structure, powder coated Hpl or ceramic top.

Padded bench is also available or with teak seat from certified plantation.

REGISTERED MODEL



LANDSCAPES '21_'22

SYSTEM

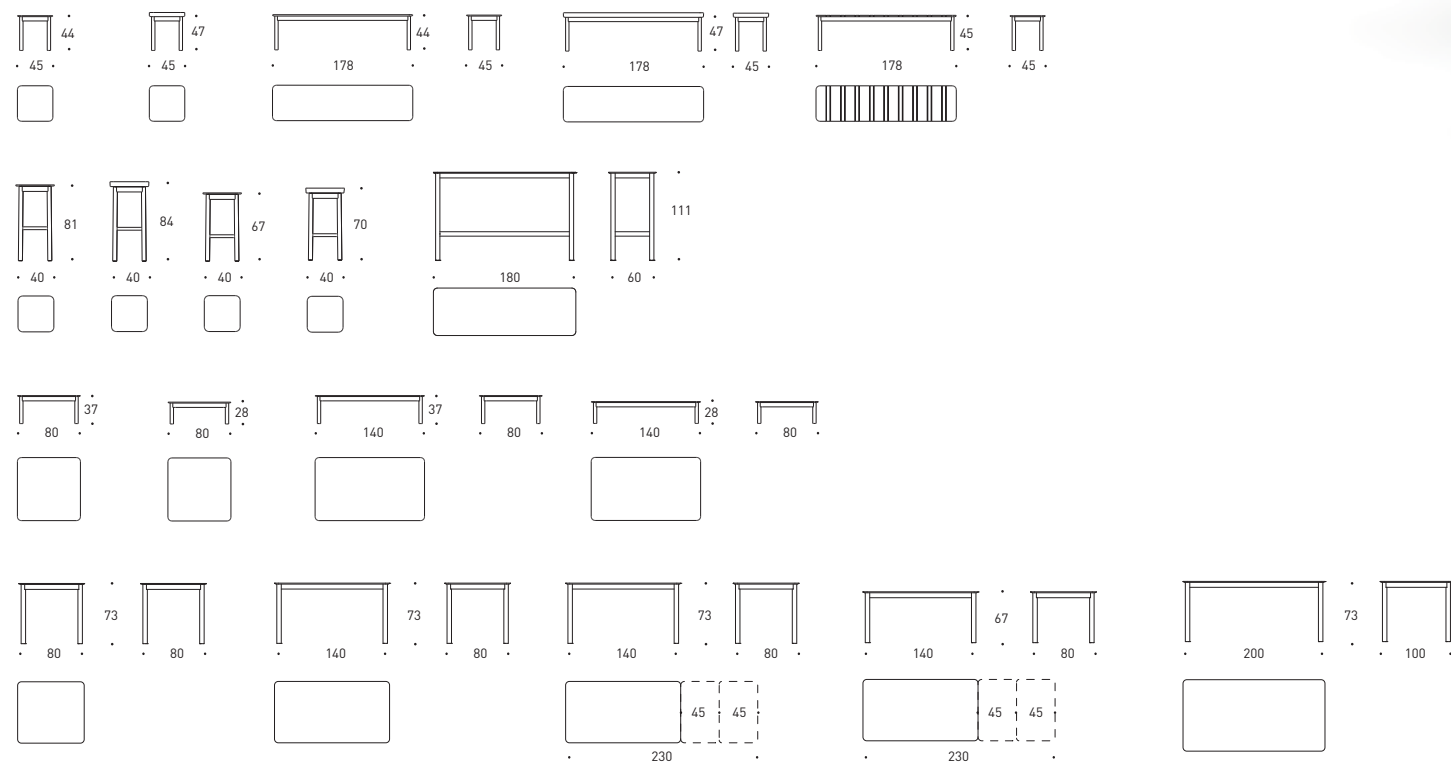

Altezza riferita con top Hpl e ceramica / Height reported with Hpl and ceramic top.



system allungabile

EXTENDABLE TABLE

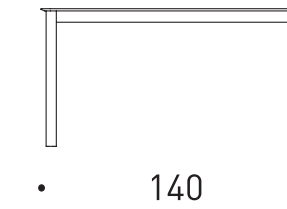
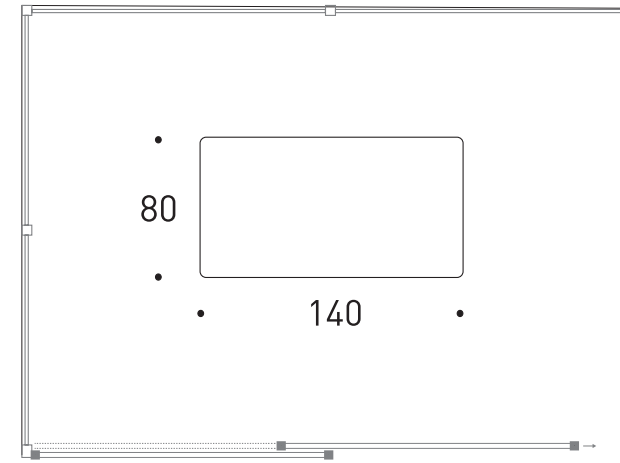

system 140

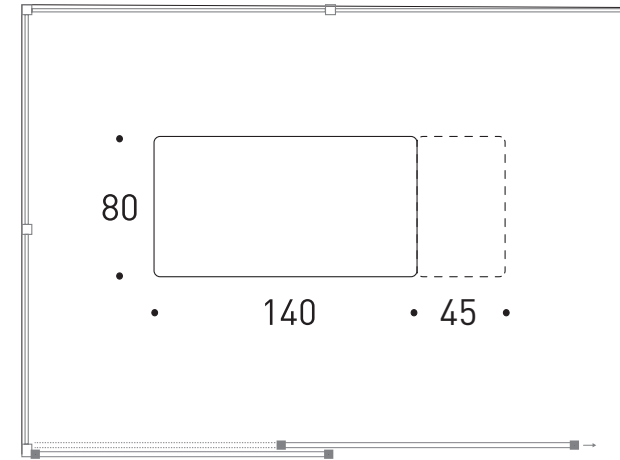

system 185

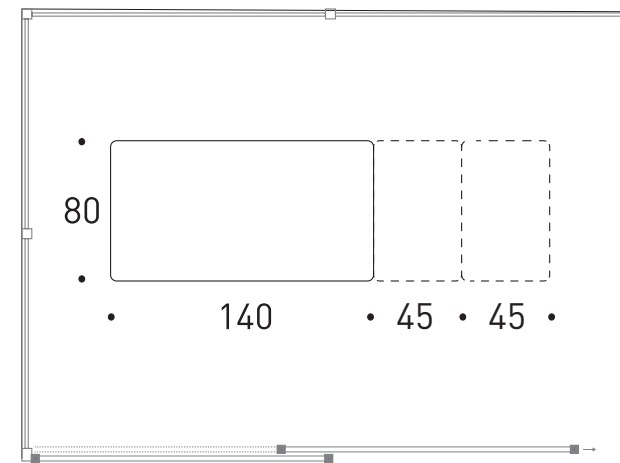

system 230









OUTDOOR THERAPY IS
celebrate
everyday

LANDSCAPES '21_'22



Sono le cose semplici che danno colore e gusto alle nostre giornate. Un bicchiere di vino, una risata con gli amici di sempre. La spensieratezza di questi momenti impreziosisce la vita di tutti i giorni. Solo apprezzando i dettagli delle piccole cose riusciamo a fare della nostra quotidianità un regalo prezioso.

It's the simple things that give color and taste to our days. A glass of wine, a laugh with old friends. The lightheartedness of these moments embellishes everyday life. Only by appreciating the details of small things can we make our daily life a precious gift.



SYSTEM



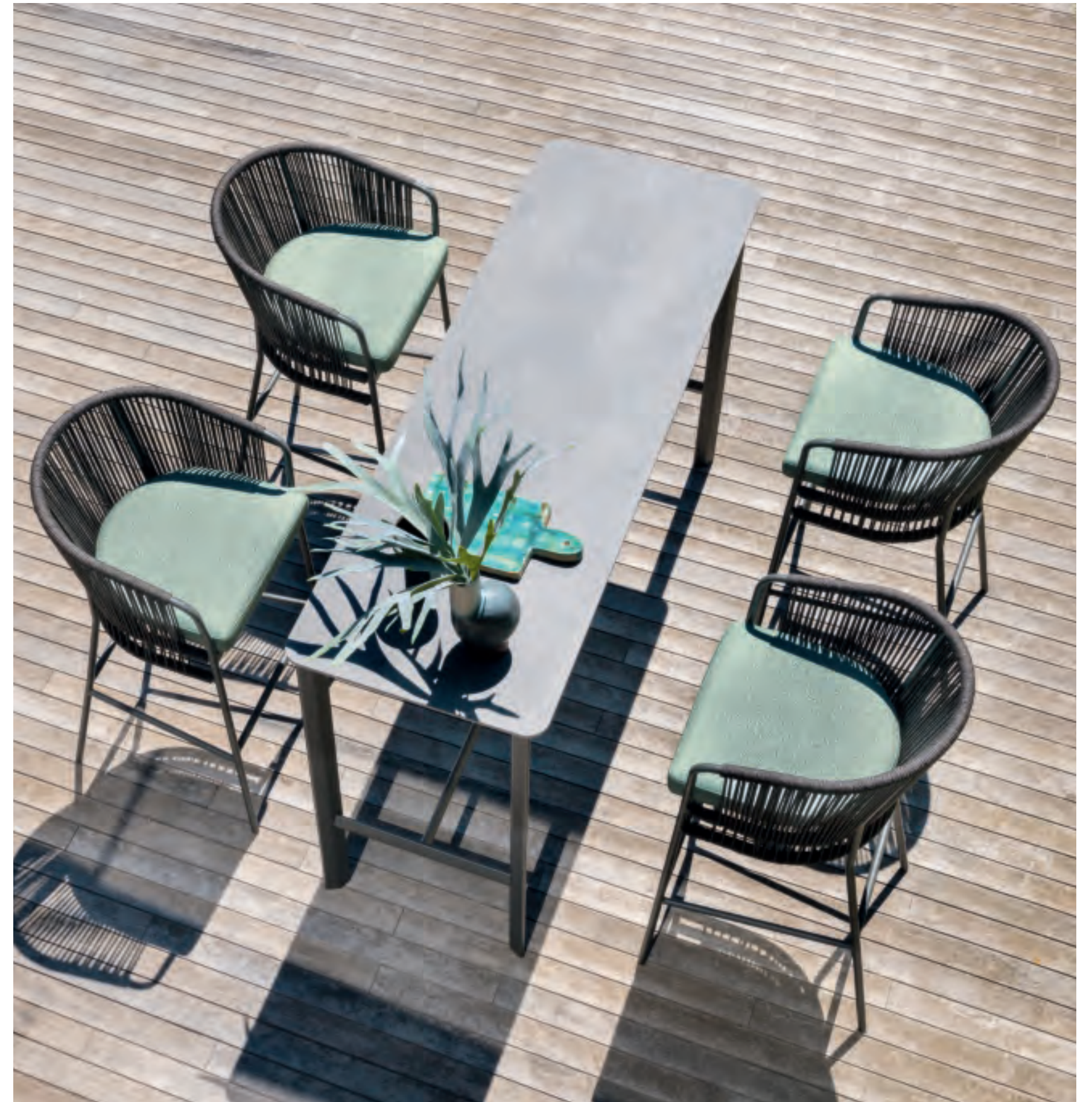





barcode

design
Alessandro Dubini

Collezione composta da divano componibile,
lettini, tavolini, consolle e lanterne realizzati in teak di
piantazione certificata.

MODELLO REGISTRATO

*Collection of modular sofas, sunbeds, coffee tables,
console and candleholder of plantation certified
solid teak.*

REGISTERED MODEL

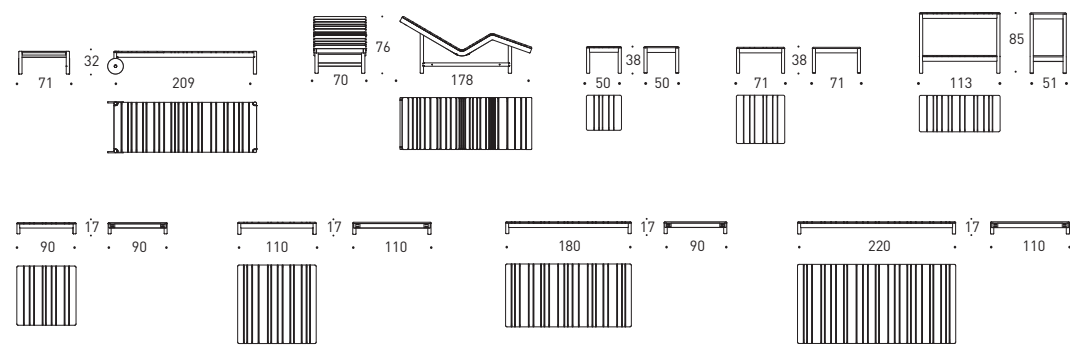







modularità

MULTIPLE SOLUTIONS



22813S

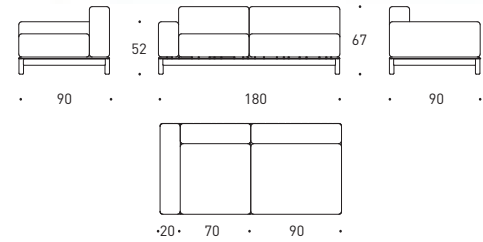

22816S

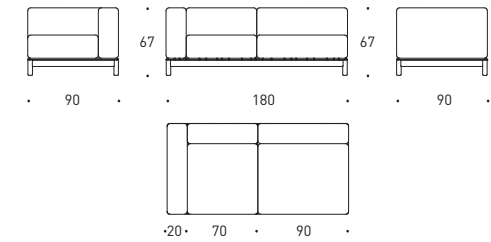

22843S

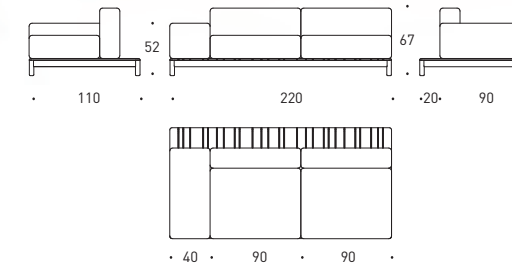

22841S

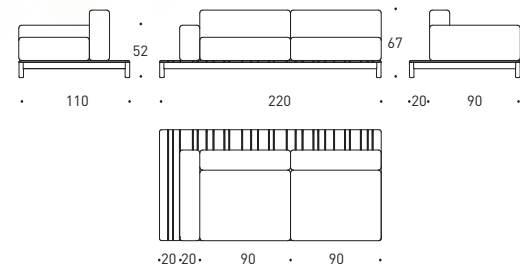

22842S

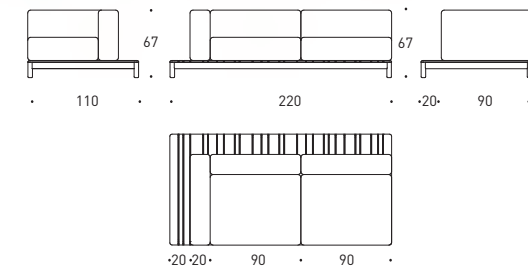

22832S

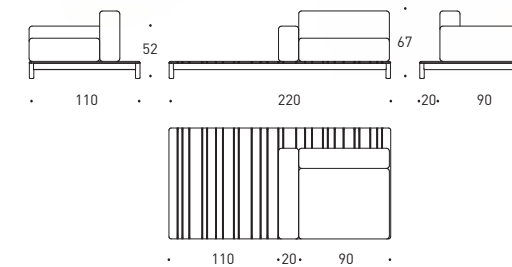

22834S

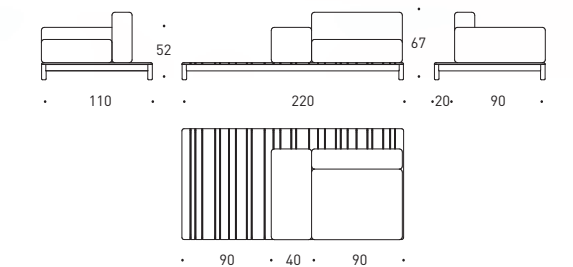







bali

design
Alessandro Dubini

Collezione con struttura portante a vista in legno massello di teak di piantagione certificata. Sedute e schienali imbottiti con gomme Dryfeel da esterno.

MODELLO REGISTRATO

Collection in solid teak wood from certified plantation. Padded seat and backs with Dryfeel outdoor foam.

REGISTERED MODEL

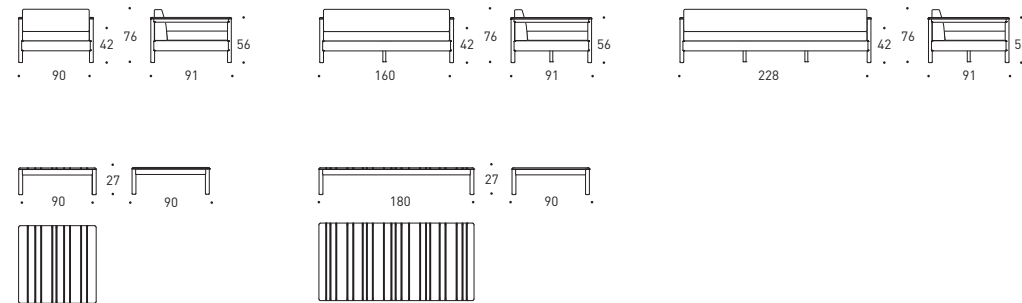













alessandro dubini

TALKS ABOUT BALI

LANDSCAPES '21_'22

L'idea che sta alla base del progetto BALI è quella di creare una silhouette classica e senza tempo, ma disegnando una struttura più contemporanea e leggera e, allo stesso modo, conferendo uno spazio di relax il più confortevole possibile. Le forme sono essenziali, fatte di linee pulite che accentuano la ricchezza del legno, il quale, insieme alla morbidezza dei cuscini, crea un tutt'uno raffinato e di stile, leggero e maneggevole, arredando con il massimo comfort.

The main idea behind the conception of BALI was to create a timeless, classic silhouette, designing a more contemporary, lighter structure, but delivering, nonetheless, the most agreeable and enjoyable relaxation space. The outline is essential, made of clean lines that accentuate the richness of the wood, which, together with the soft, cushioned seating provides a refined, stylish ensemble, light and easy to handle, while furnishing with the maximum comfort.

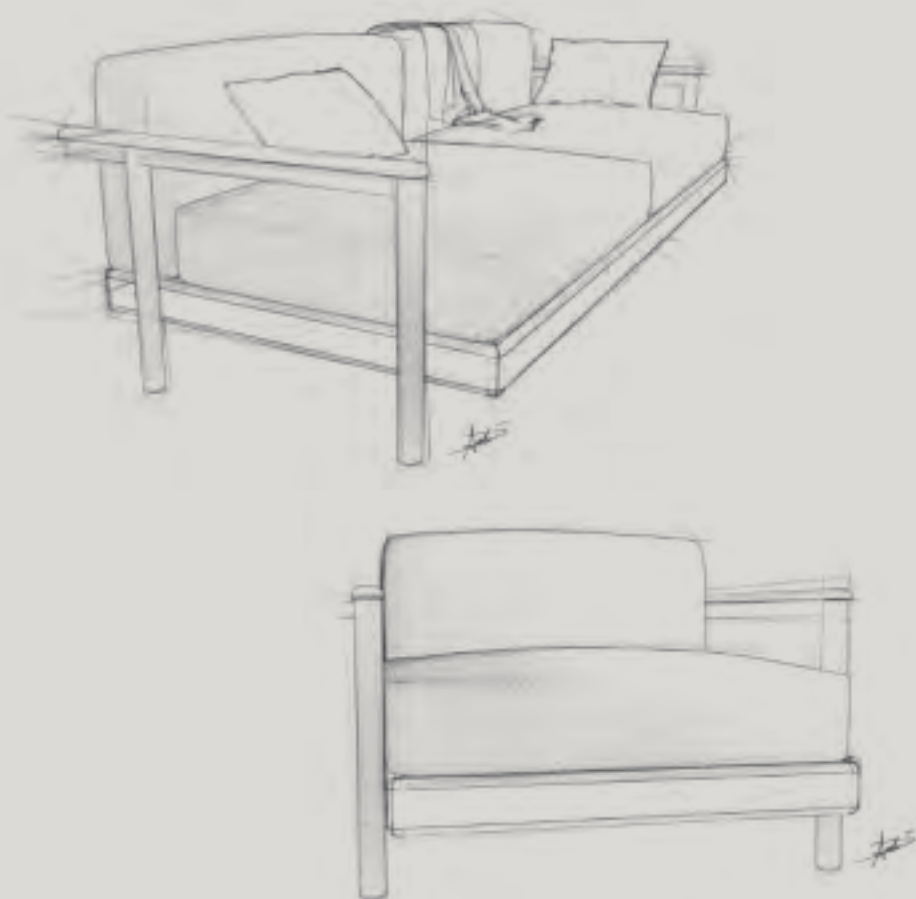

BALI

bali bèrgere deck relax

design
Daniele Lo Scalzo Moscheri

Collezione con struttura portante a vista in legno massello di teak di piantagione certificata. Sedute e schienali imbottiti con gomme Dryfeel da esterno.

MODELLO REGISTRATO

Collection in solid teak wood from certified plantation.

Padded seat and backs with Dryfeel outdoor foam.

REGISTERED MODEL

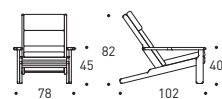





OUTDOOR THERAPY IS
sunrise
inspired

I riflessi del nuovo giorno sulla superficie dell'acqua sono il paesaggio di ispirazione che preferisco. Comincio sempre la mia giornata apprezzando i colori speciali di questo momento magico ed intimo che risveglia la vita.

Reflections of a new day on the surface of water are my favorite inspirational landscape. I always start my day appreciating special colors of this magical and intimate moment that awakens life.



noSS

design
Edoardo Gherardi

Poltroncina con struttura in tubo di alluminio e sedile in lamiera di alluminio spessore 15/10 verniciati a polveri. Schienale intrecciato a mano con corda in fibra sintetica (polipropilene) Light o Brown Line. Cuscino opzionale con imbottitura in gomma Dryfeel da esterno.

MODELLO REGISTRATO

Dining armchair with aluminum frame and seat in powder-coated aluminum sheet, 15/10 thickness. Hand woven back with synthetic fiber rope (polypropylene) Light Line or Brown Line. Optional cushion with Dryfeel foam padding for outdoor use.

REGISTERED MODEL



LANDSCAPES '21_'22

noSS

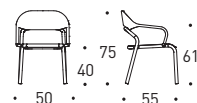
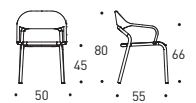



77_12_14

NOSS





LANDSCAPES '21_'22



Noss Low H40



Noss H45

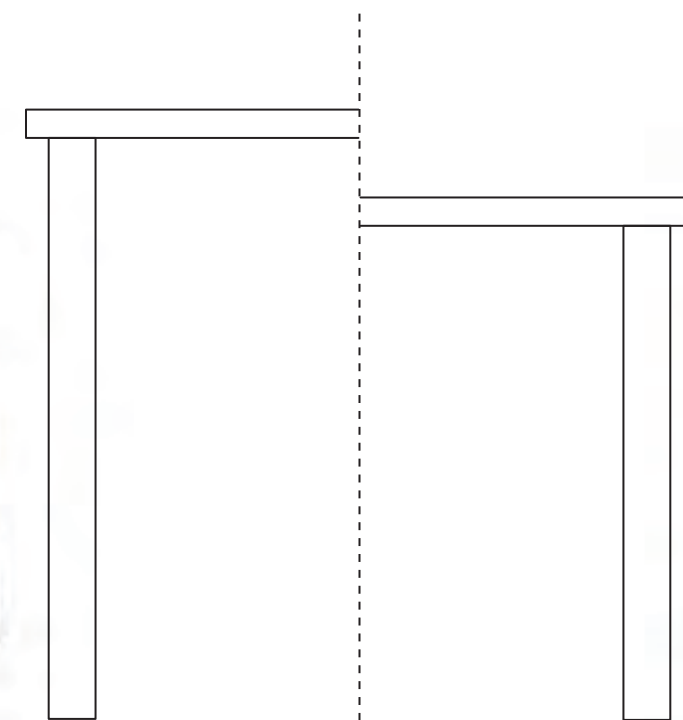

Noss Low H40



NOSS







edoardo gherardi

TALKS ABOUT NOSS

Composta di parti distinte ma tra loro corrispondenti e armonicamente disposte, Noss unisce tecnologia e innovazione. Un nastro strutturale armonioso e leggero, caratterizza il progetto in un perfetto equilibrio fra le parti in cui linee morbide e accoglienti abbracciano robustezza e solidità. Per Noss il bilanciamento tra comodità, funzionalità e ricerca di un design innovativo, si unisce a materiali tecnologicamente avanzati in una alchimia di forme e funzioni, le quali trovano la massima valorizzazione nell'antica esperienza delle lavorazioni ad intreccio.

Composed of distinct but corresponding parts harmoniously arranged, Noss, combines technology and innovation. A structural rope, harmonious and light characterizes the project in a perfect balance between the parts in which soft and welcoming lines embrace strength and solidity.

For Noss, the balance between comfort, functionality and research for an innovative design joins technologically advanced materials in an alchemy of shapes and functions, which find the maximum value in the ancient experience of weaving.

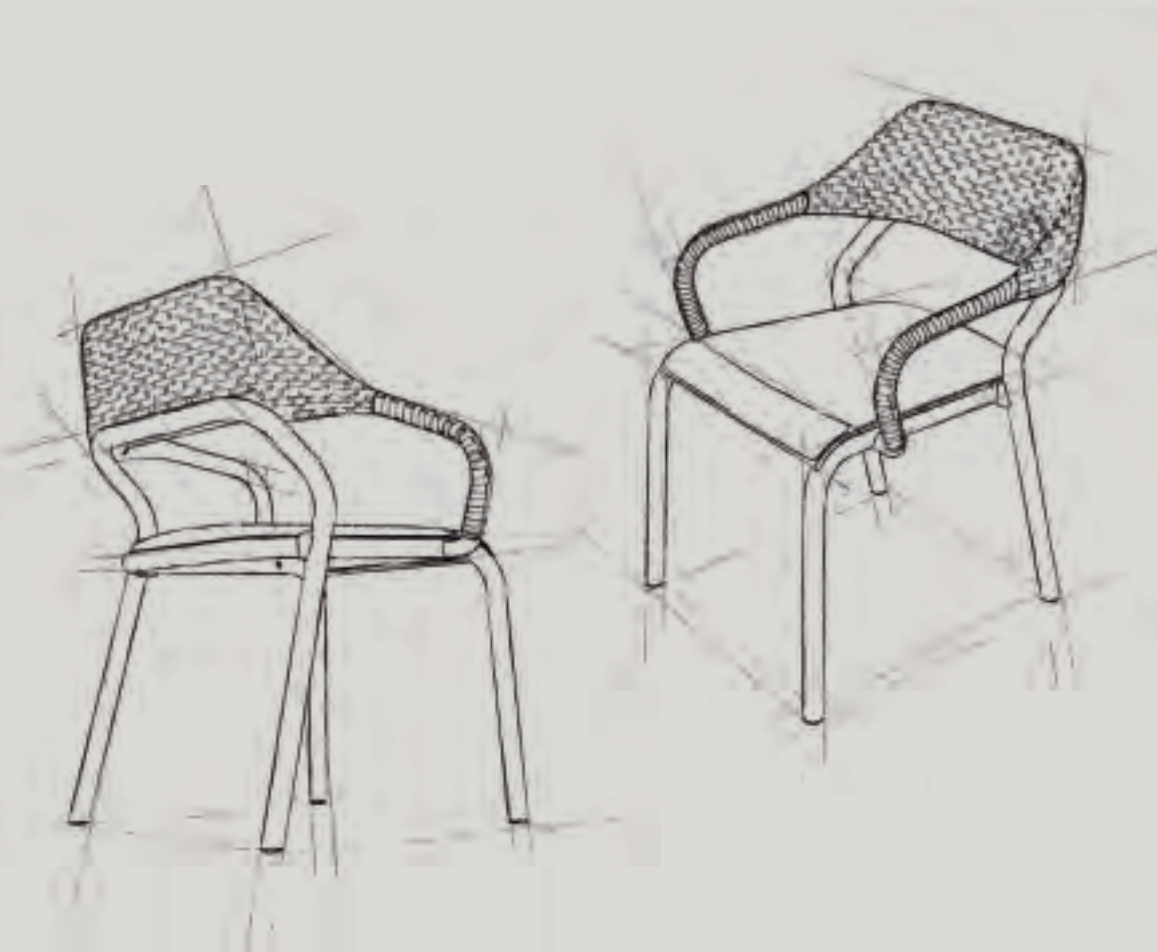

clever

design
R&D Varaschin

Collezione di sedute composta da poltroncina, poltrone, divano, dondolo, sdraio e sgabello con struttura in alluminio verniciato a polveri, sedute e schienali in VAR#TEX (tessuto tecnico in PVC). Disponibile anche versione con seduta texture e schienale in cordino sintetico.

MODELLO REGISTRATO

Seating collection composed of chairs, armchairs, sofa, rocking armchair, foldable deckchair and stool with powder coated aluminum frame, seat and back in VAR#TEX (PVC based material). Also available with texture seat and backrest in synthetic rope.

REGISTERED MODEL

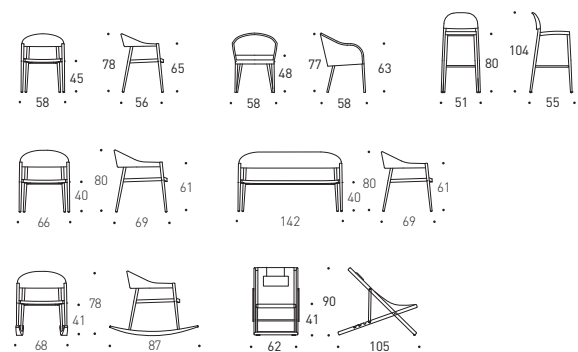



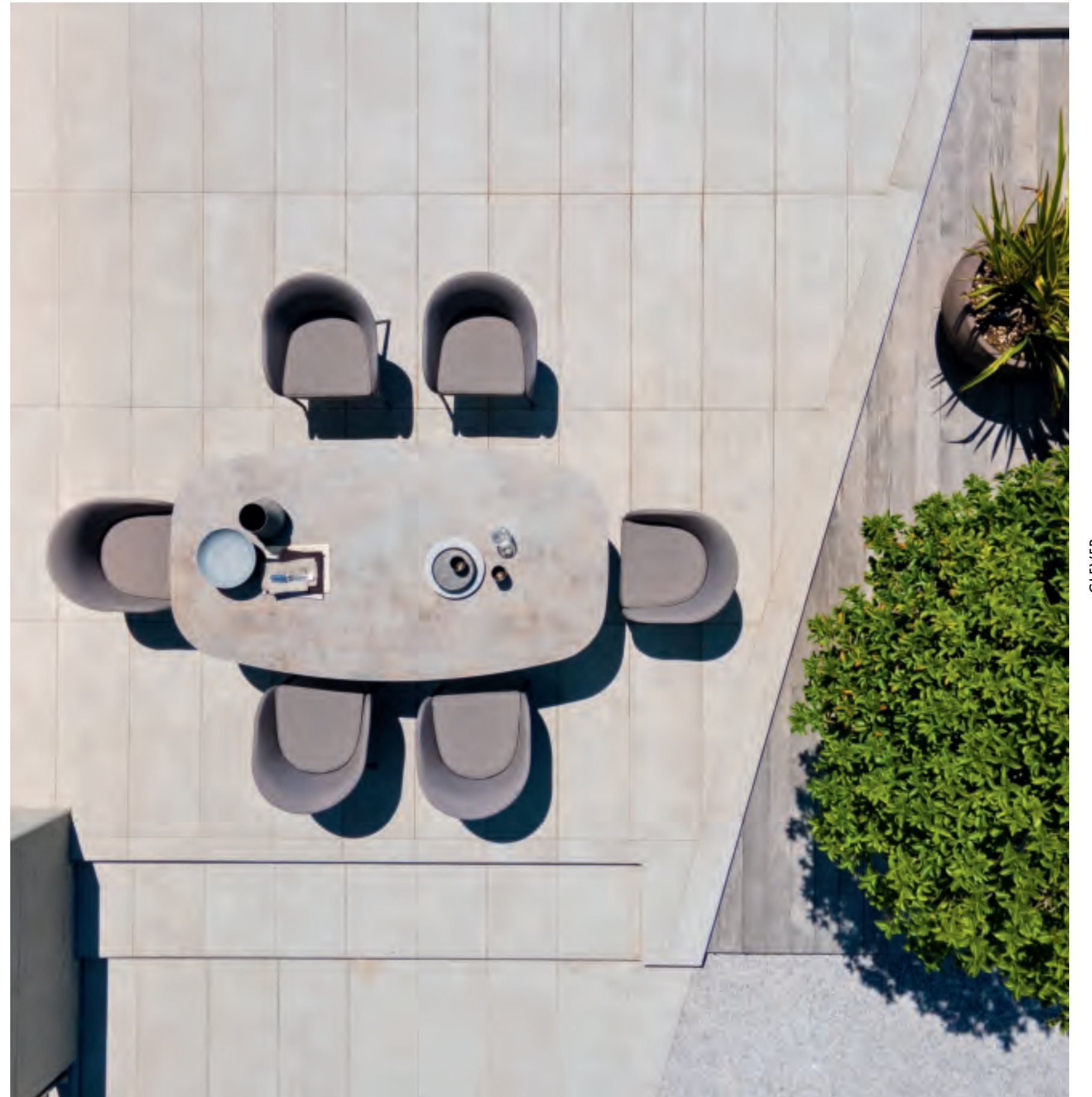



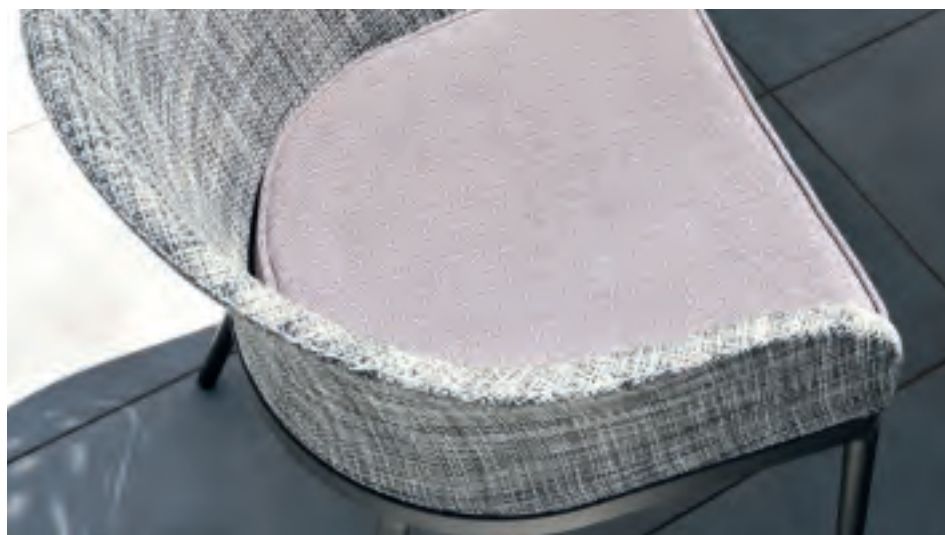









LANDSCAPES 2023

CLEVER

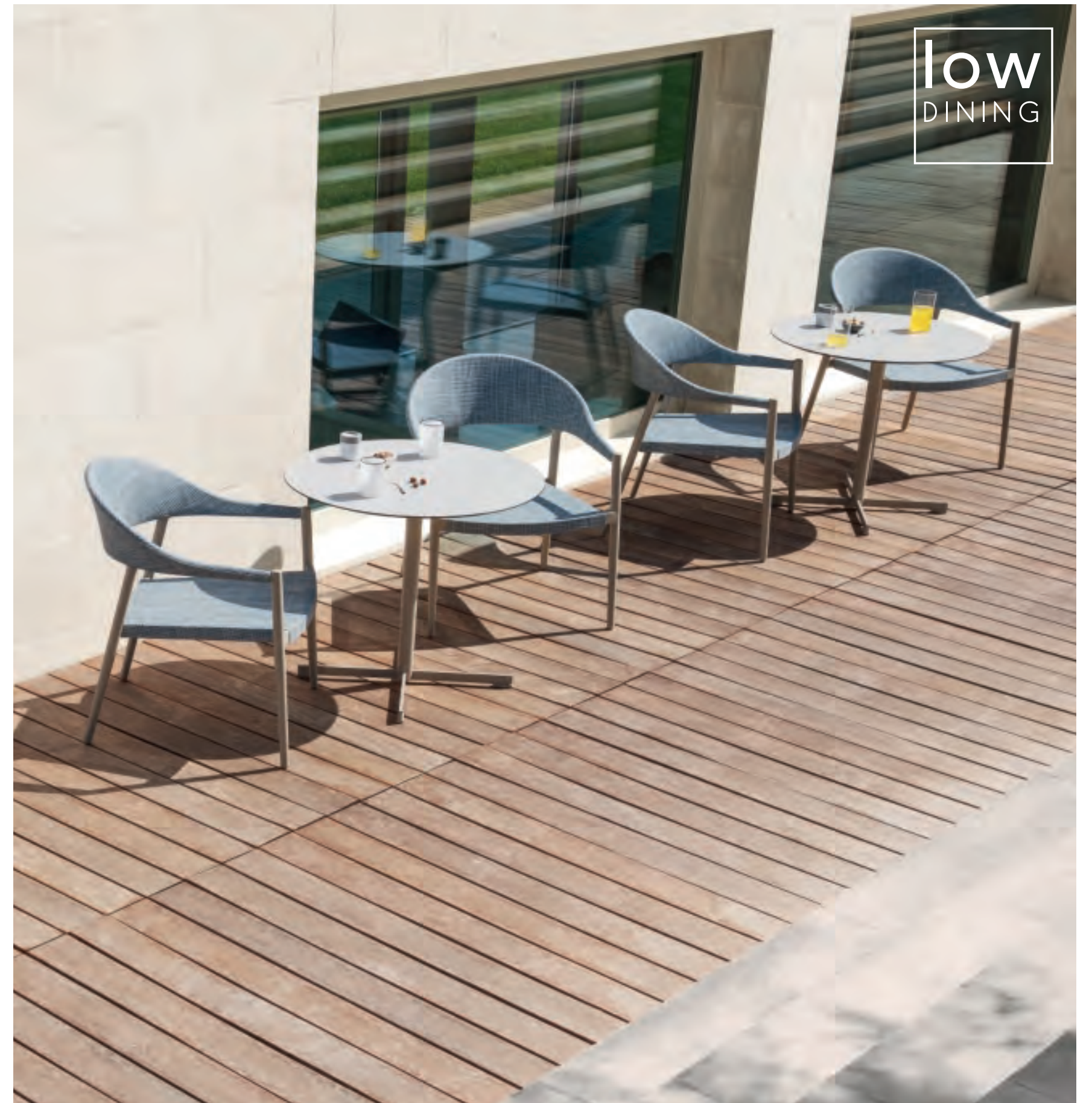



LANDSCAPE

CLEVER











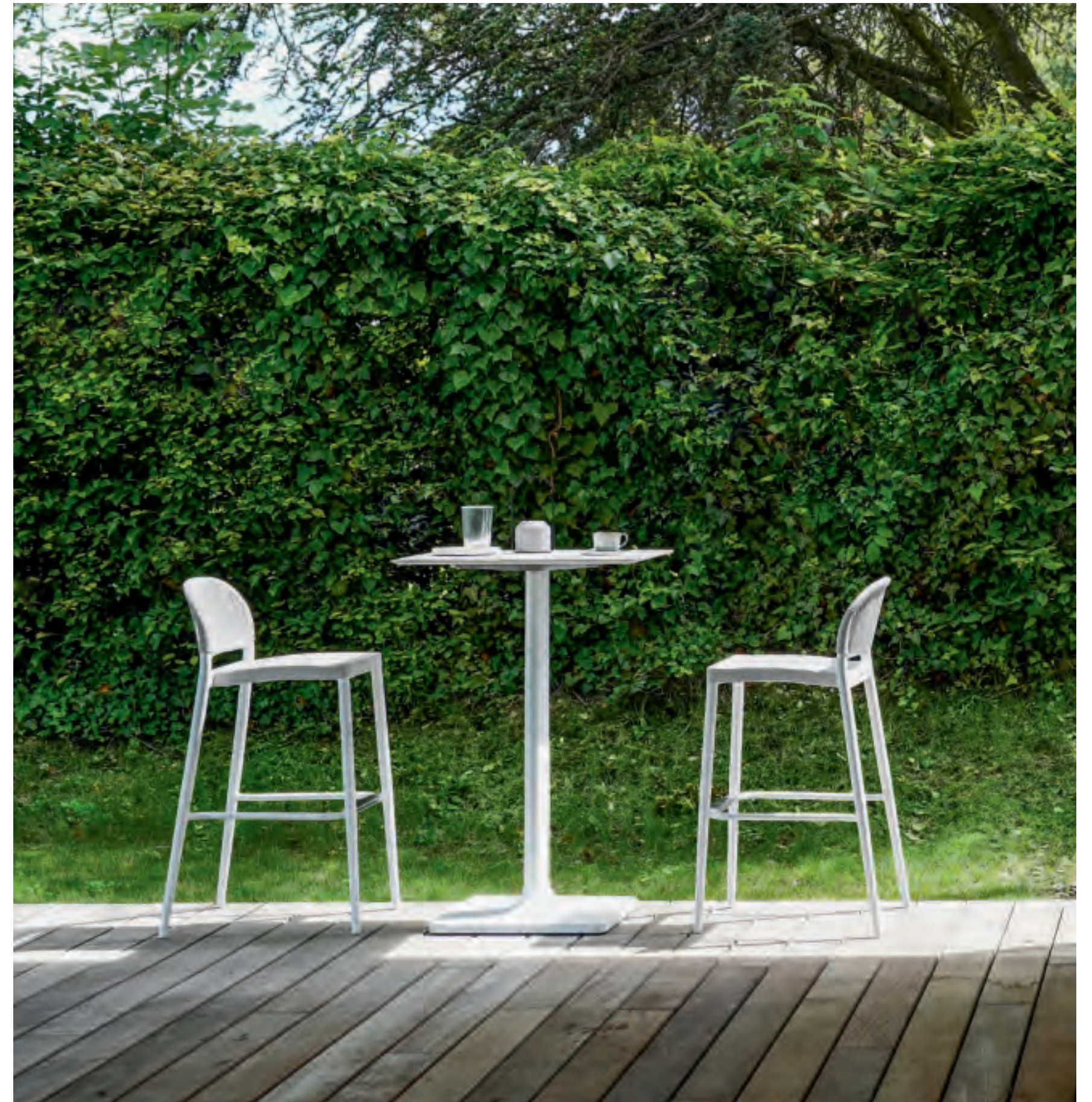
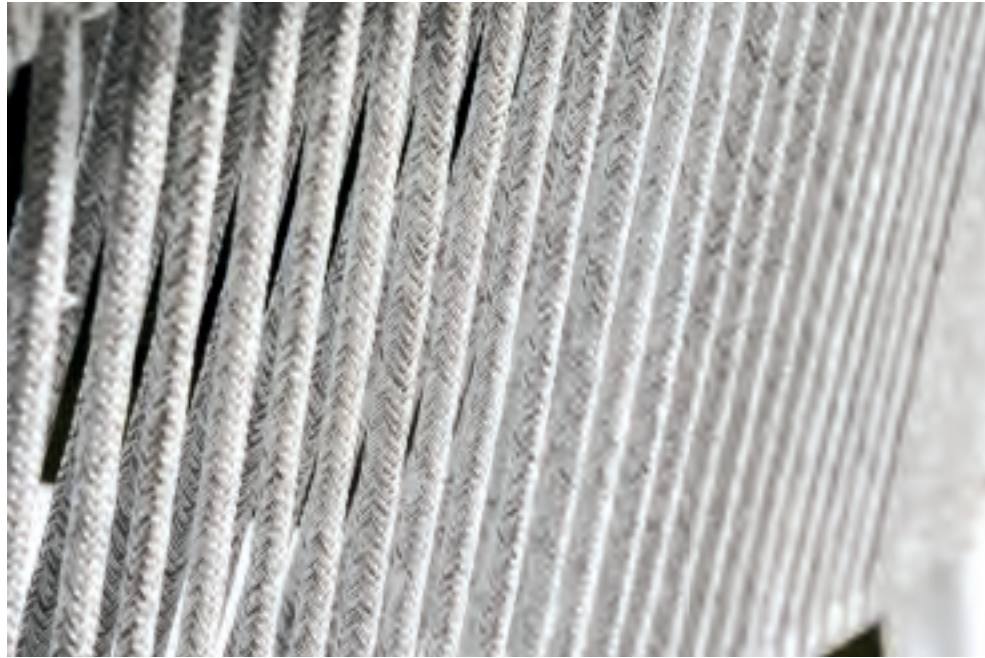

struttura grigio
GREY STRUCTURE



POLTRONCINA
DINING ARMCHAIR
VAR#TEX CENERE



POLTRONCINA
DINING ARMCHAIR
VAR#TEX CENERE



POLTRONA LOUNGE
LOUNGE ARMCHAIR
VAR#TEX CENERE



DONDOLO POLTRONA LOUNGE
ROCKING LOUNGE ARMCHAIR
VAR#TEX CENERE



DIVANO 2 POSTI
2 SEATER SOFA
VAR#TEX CENERE



SGABELLO
STOOL
VAR#TEX CENERE



SDRAIO PIEGHEVOLE
FOLDABLE DECKCHAIR
VAR#TEX CENERE

struttura grigio seta
SILK GREY STRUCTURE



POLTRONCINA
DINING ARMCHAIR
VAR#TEX ACQUERELLO



POLTRONCINA
DINING ARMCHAIR
VAR#TEX ACQUERELLO



POLTRONA LOUNGE
LOUNGE ARMCHAIR
VAR#TEX ACQUERELLO



DONDOLO POLTRONA LOUNGE
ROCKING LOUNGE ARMCHAIR
VAR#TEX ACQUERELLO



DIVANO 2 POSTI
2 SEATER SOFA
VAR#TEX ACQUERELLO



SGABELLO
STOOL
VAR#TEX ACQUERELLO



SDRAIO PIEGHEVOLE
FOLDABLE DECKCHAIR
VAR#TEX ACQUERELLO

LANDSCAPES '21_'22

CLEVER

struttura bianco
WHITE STRUCTURE



POLTRONCINA
DINING ARMCHAIR
VAR#TEX BIANCO



POLTRONCINA
DINING ARMCHAIR
VAR#TEX BIANCO



POLTRONA LOUNGE
LOUNGE ARMCHAIR
VAR#TEX BIANCO



DONDOLO POLTRONA LOUNGE
ROCKING LOUNGE ARMCHAIR
VAR#TEX BIANCO



DIVANO 2 POSTI
2 SEATER SOFA
VAR#TEX BIANCO



SGABELLO
STOOL
VAR#TEX BIANCO



SDRAIO PIEGHEVOLE
FOLDABLE DECKCHAIR
VAR#TEX BIANCO

link design
Alain Gilles

Collezione di tavoli allungabili e fissi, con struttura realizzata in metallo verniciato a polveri.
Gambe disponibili in metallo e teak.
Piani di diverse tipologie e finiture.

MODELLO REGISTRATO

Collection of extendable and fixed tables with powder coated metal structure.
Legs available in metal and teak.
Tops in various materials and finishes.

REGISTERED MODEL

LANDSCAPES '21_'22

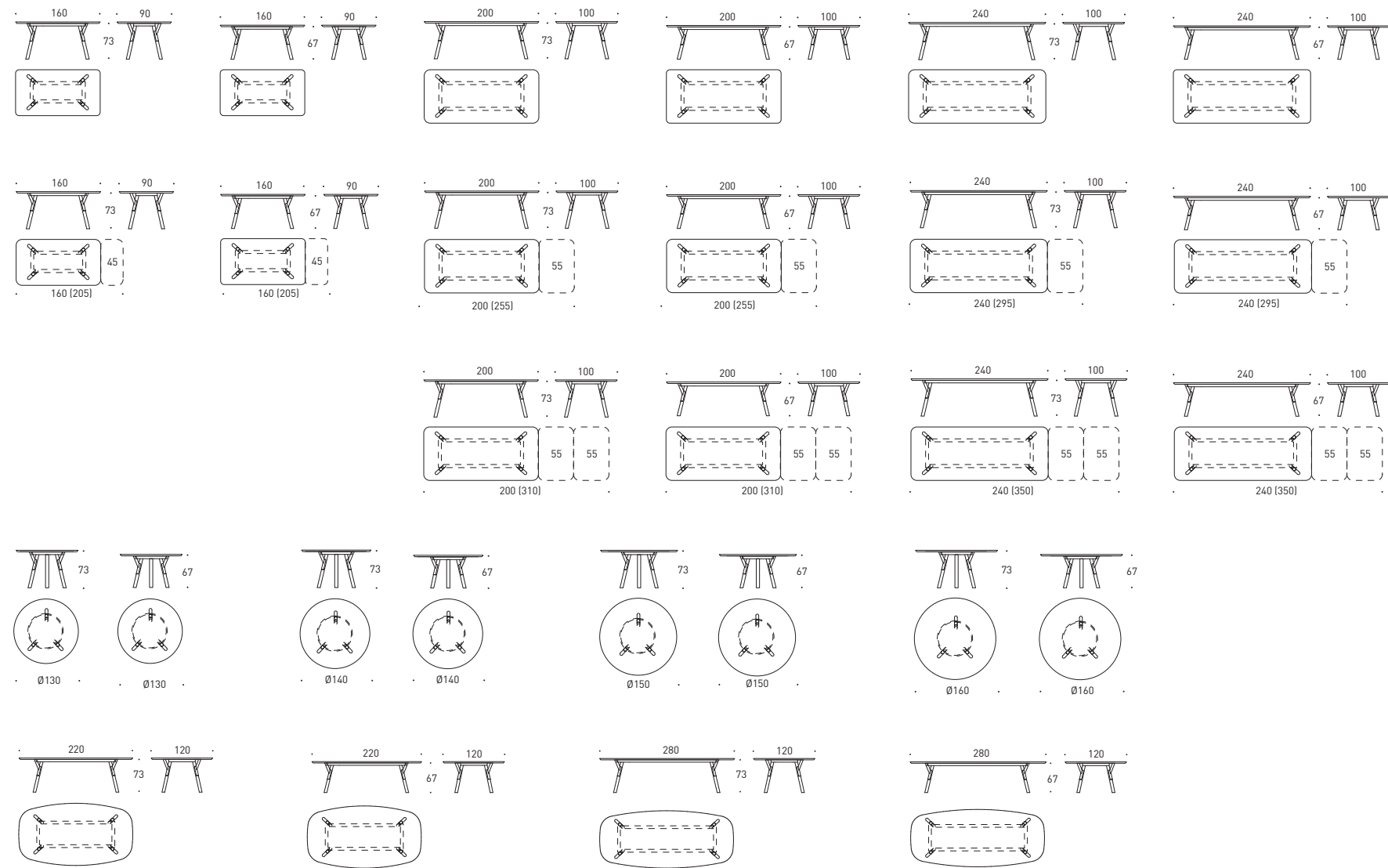

Altezza riferita con top Hpl / Height reported with Hpl top



LINK





link allungabile

EXTENDABLE TABLE

LANDSCAPES '21_'22



200 mm

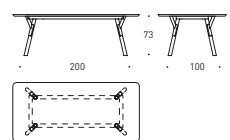

255 mm

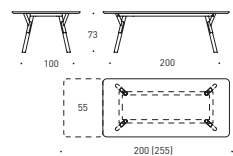

310 mm

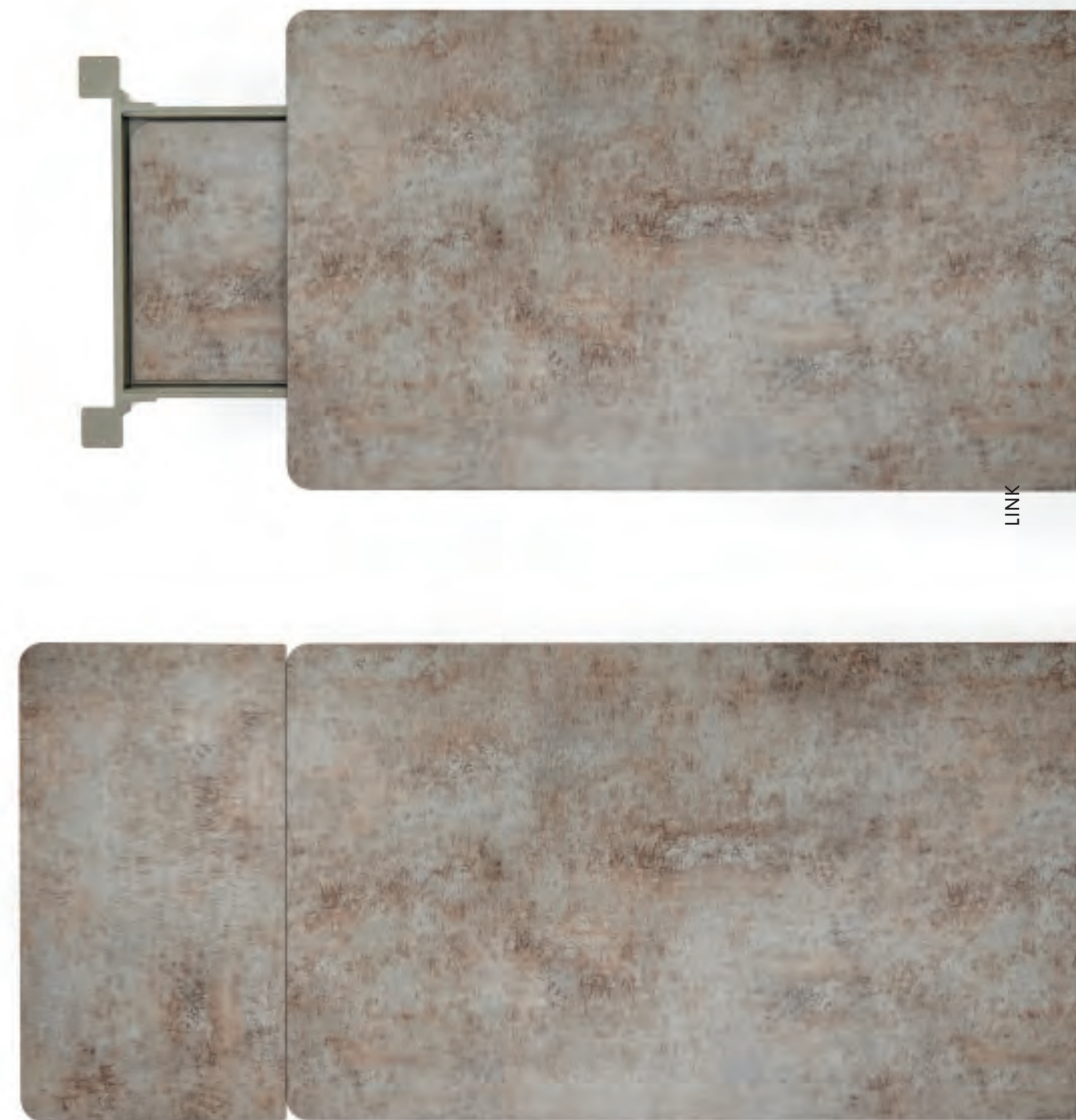
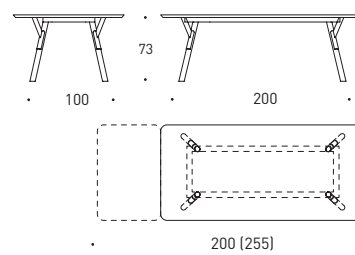
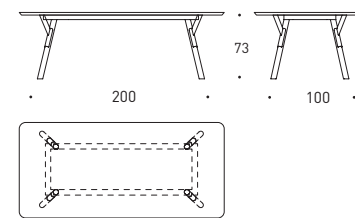
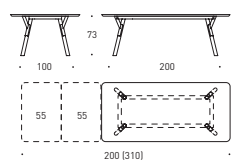

LINK

Altezza riferita con top Hpl / Height reported with Hpl top



© 2022 LINK

LINK











alain gilles

TALKS ABOUT LINK

LANDSCAPES '21_'22

Il design di questo tavolo si incentra sul collegamento, il "link" metallico che rinforza strutturalmente le gambe in legno. Senza questo "link" le gambe del tavolo, aventi un angolo molto ampio, potrebbero rompersi. Il link permette infatti di creare un design più dinamico e accentuato.

Il modo in cui questo giunto metallico è unito alla struttura tondeggiante delle gambe in legno, ricorda i giunti dei tradizionali attrezzi da giardino. È una sorta di connessione tra legno e acciaio a basso contenuto tecnologico, ma lavorata in modo più grafico e ridefinito.

The design of this table is all about the connection, the "link" that structurally re-enforces the wooden legs. Without this "link" the legs of the table that have a very open angle could break. Hence, this link allows us to create a more dynamic and dramatic design.

The way the metal link is joined to the round wooden leg is reminiscent of the type of connection that can be found on some old traditional garden tools. It is a sort of low-tech connection between steel and wood but worked in a more graphic and refined manner.

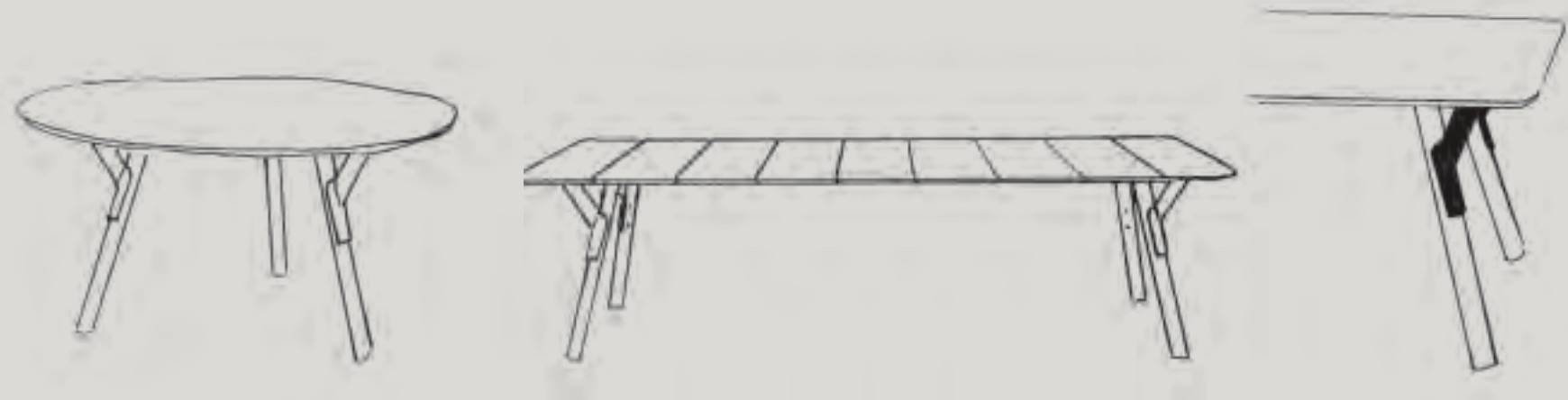

LINK

victor

design
R&D Varaschin

Collezione con struttura in alluminio verniciato a polveri, sedute e schienali in tessuto traforato batyline, differenti cromie o tessuti resistenti alla tensione.

Collection with powder coated aluminium frame, seat and backrest in batyline in different colours or fabrics resilient to tension.



LANDSCAPES '21_'22

VICTOR

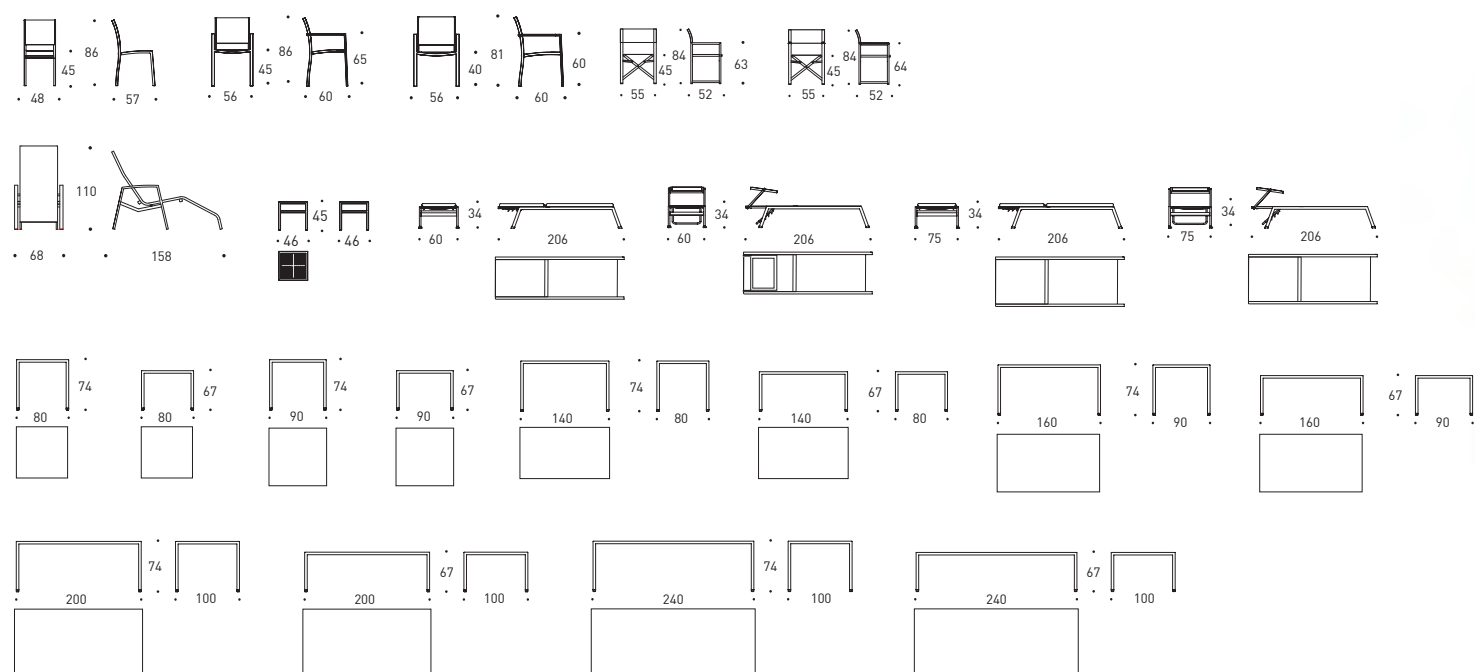

Altezza riferita con top Hpl / Height reported with Hpl top



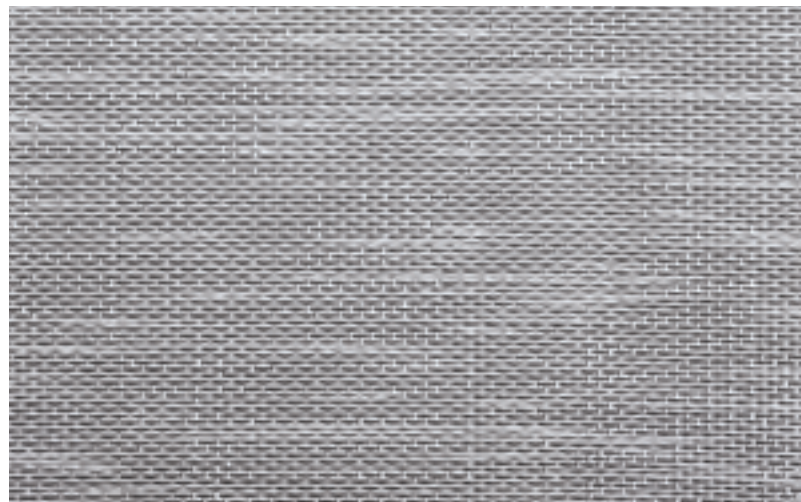























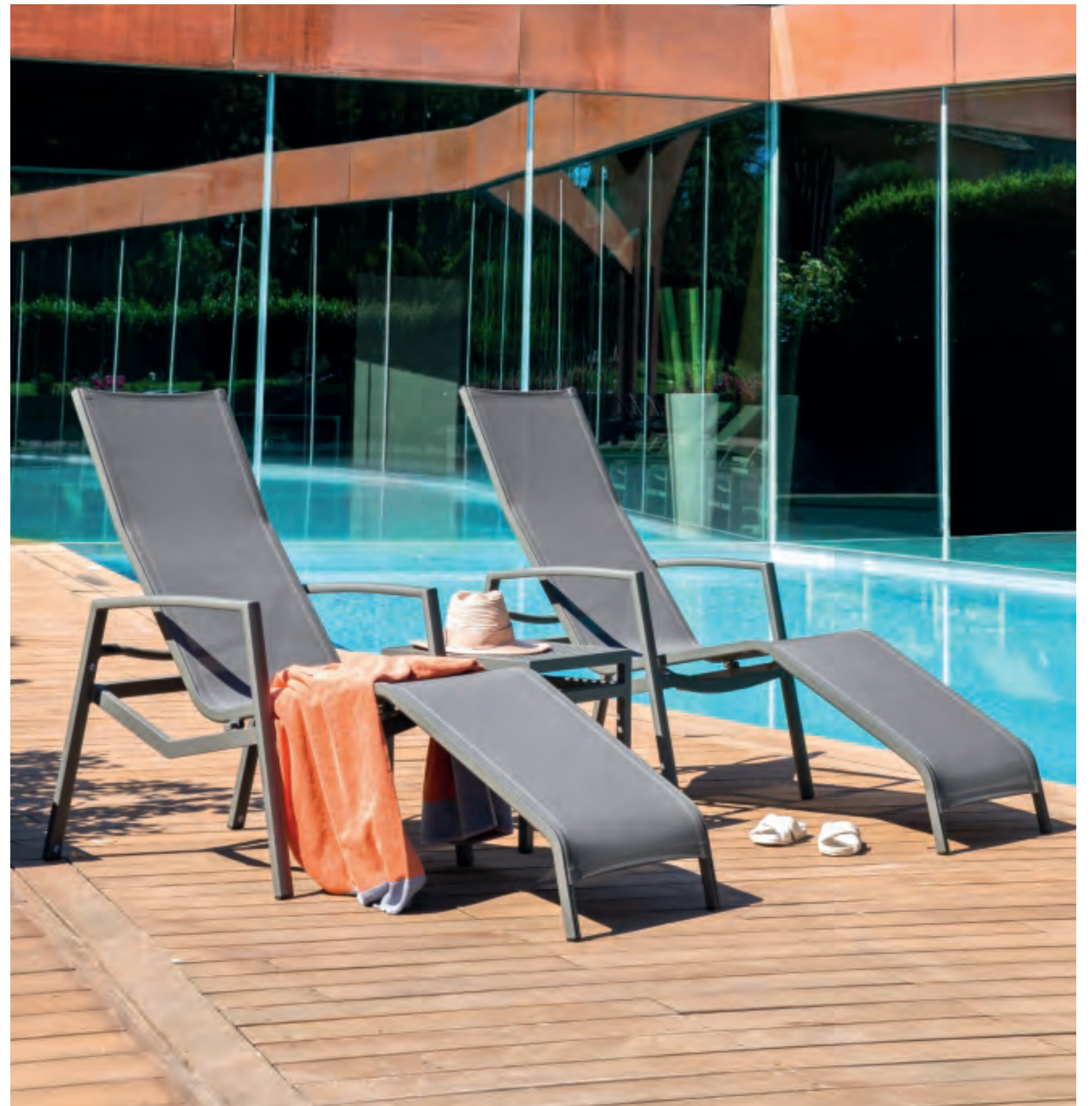

lapis

design
Calvi Brambilla

Collezione con struttura in legno massello di teak di piantagione certificata. Scocca con telai di alluminio verniciato a polveri intrecciata a mano, alternativa scocca in multistrato di legno per esterni rivestita in tessuto ed imbottita con gomma Dryfeel da esterno.

MODELLO REGISTRATO

Collection with structure made of wood from certified plantation. Shell in aluminum, powder coated, hand woven, or outdoor plywood shell upholstered with fabric and Dryfeel outdoor foam.

REGISTERED MODEL

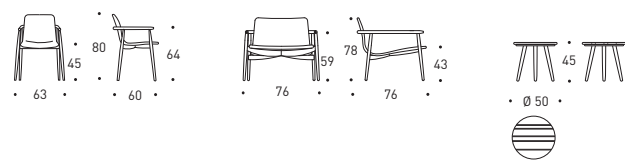







low
DINING



LANDSCAPES '21_'22

LAPIS

bento

design
Calvi Brambilla

Collezione componibile imbottita con gomme.
Versione outdoor: struttura portante in legno massello di okumé e imbottitura con gomme Dryfeel da esterno. Versione indoor: struttura portante in legno massello di abete e imbottitura in gomma da interno.

Bento si caratterizza per la possibilità di creare molteplici combinazioni che facilmente possono essere definite e successivamente anche modificate a discrezione del Cliente. È possibile, infatti, con semplici operazioni modificare più volte la combinazione iniziale ridisponendo a piacimento i moduli già acquistati. Allo stesso modo il Cliente può aggiungere moduli supplementari acquistabili in un secondo momento, rispettando semplicemente le regole di composizione.

MODELLO REGISTRATO

Modular foam padded collection.

Outdoor version: made of okumé solid wood and padded with Dryfeel outdoor foam.

Indoor version: made of fir wood and padded with standard indoor foam.

Bento allows you to create multiple combinations that can be modified at a later stage by the customer. It is, in fact, possible to change the composition on different occasions at ones leisure.

With the same thought in mind the customer can add modules at a later stage following the possible options available.

REGISTERED MODEL

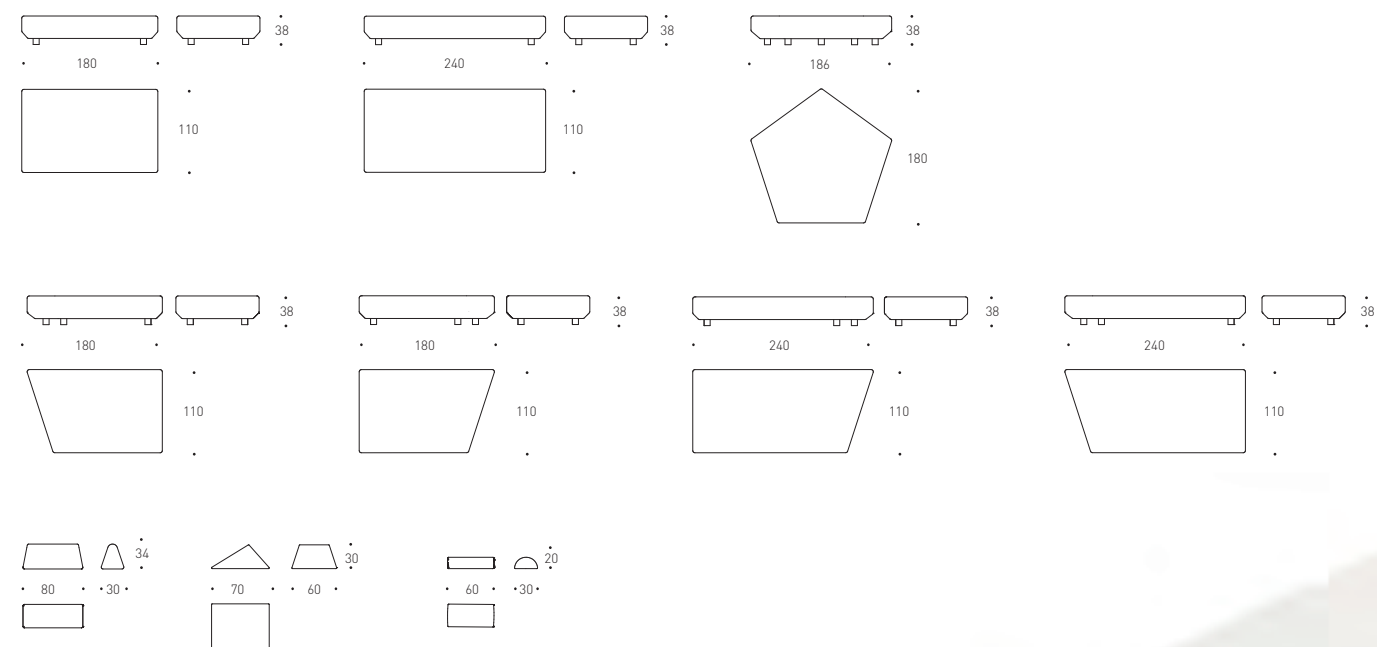







LANDSCAPES '21-'22

BENTO





soluzioni d'arredo

MULTIPLE SOLUTIONS

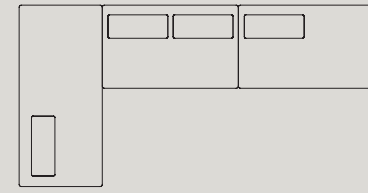

/01

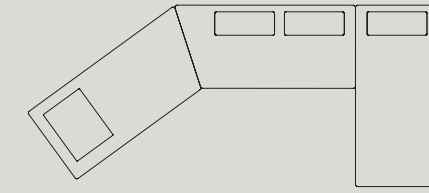

/02

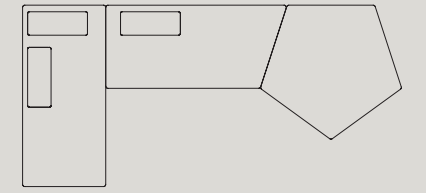

/03

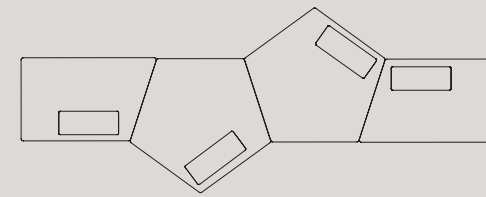

/04

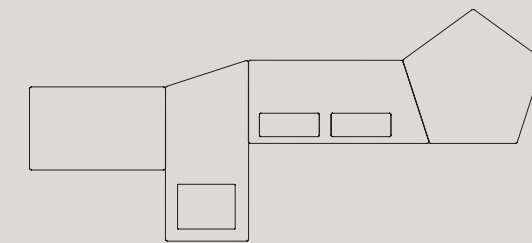

/05

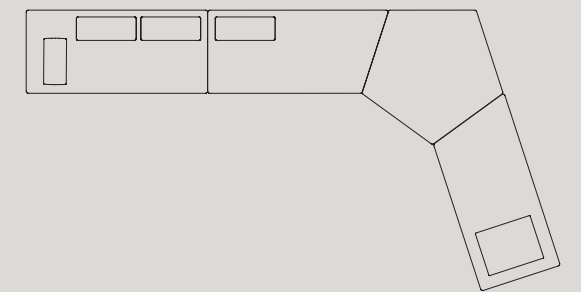

/06

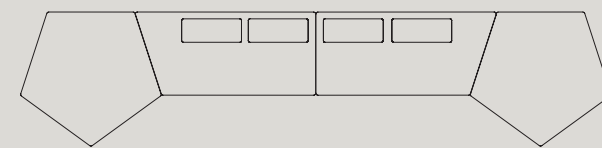

/07

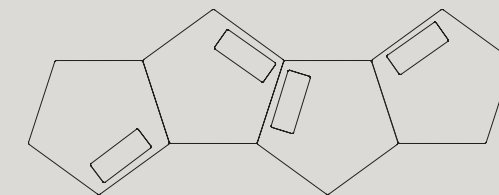

/08

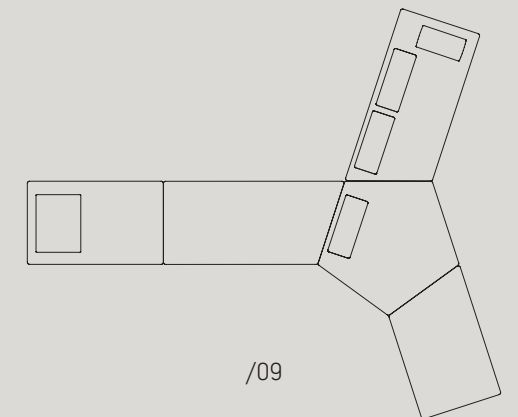

/09

BENTO

smart design

R&D Varaschin

Collezione di sedute con struttura in alluminio verniciato a polveri, seduta in tessuto tecnico VAR#TEX, schienali intrecciati in cordino sintetico VAR#TEX.

MATERIALE REGISTRATO

Collection of seats with powder-coated aluminum structure, seat in VAR#TEX technical fabric, woven backs in VAR#TEX synthetic rope.

REGISTERED MATERIAL



LANDSCAPES '21_'22

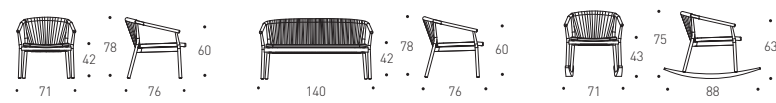
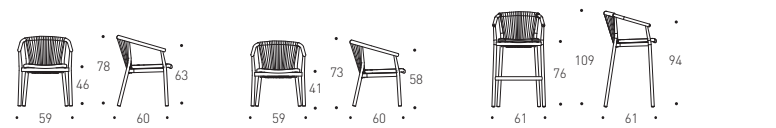





OUTDOOR THERAPY IS
juicy morning

LANDSCAPES '21_'22

La colazione è sempre il momento migliore per qualcosa di succoso, dolce e fresco, sembra proprio il modo giusto per iniziare la giornata. Preferisco sempre il colore abbinato ai sapori autentici così la nostra tavola è allegra, giocosa ed anche sana.

Breakfast is always the best moment for something juicy, sweet and fresh, it really seems the right way to start the day. I always prefer color combined with authentic flavors so our table is cheerful, playful and also healthy.



SMART



OUTDOOR THERAPY IS smart working outdoor

Come artista, come fotografo ritrattista, il mio lavoro è dire la verità e catturare lo spirito di qualcuno in un determinato giorno. Quando le parole non sono chiare, mi concentro sulle fotografie. Quando le immagini diventano inadeguate, mi accontenterò del silenzio.

As an artist, as a portrait photographer, my job is to tell the truth and capture someone's spirit on a certain day. When words are not clear, I focus on photographs. When images become inadequate, I will be content with silence.

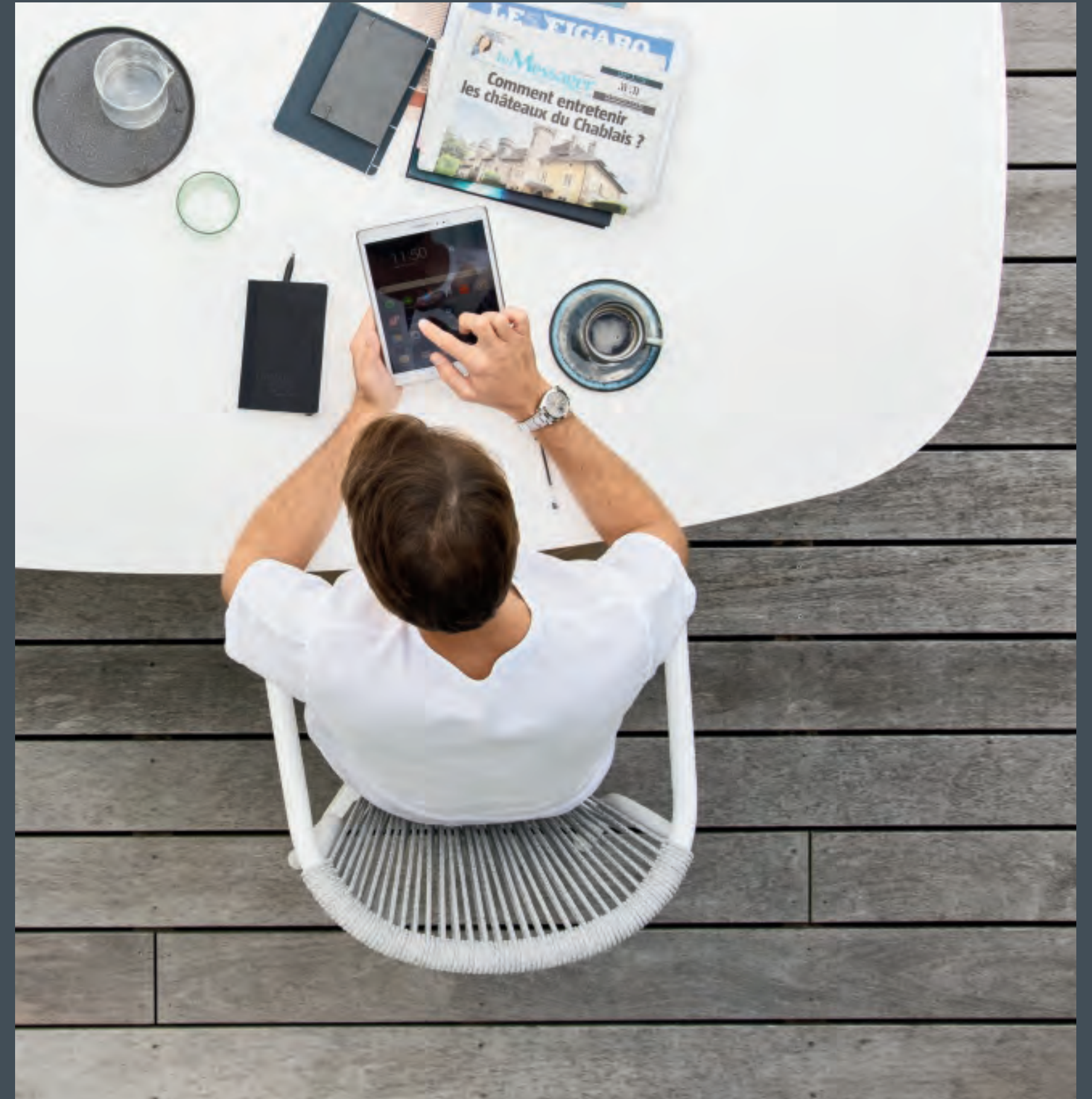





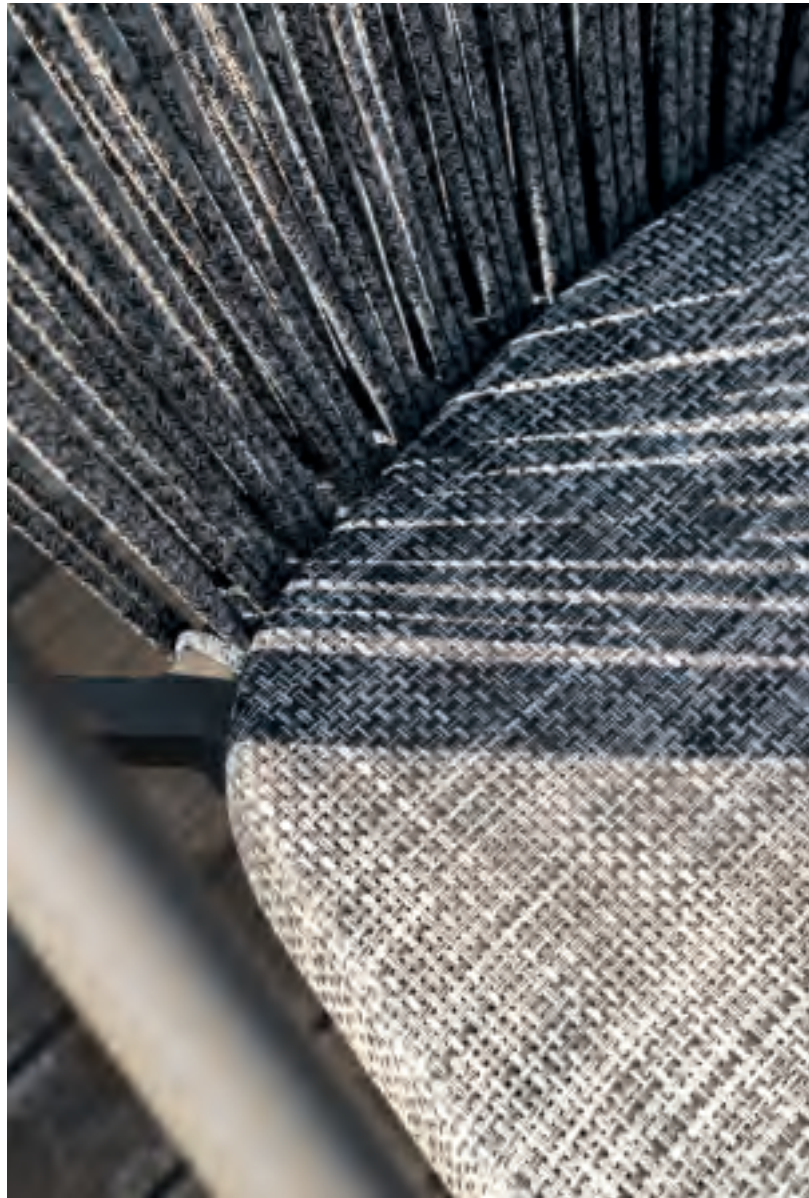



LANDSCAPES '21 '22

SMART

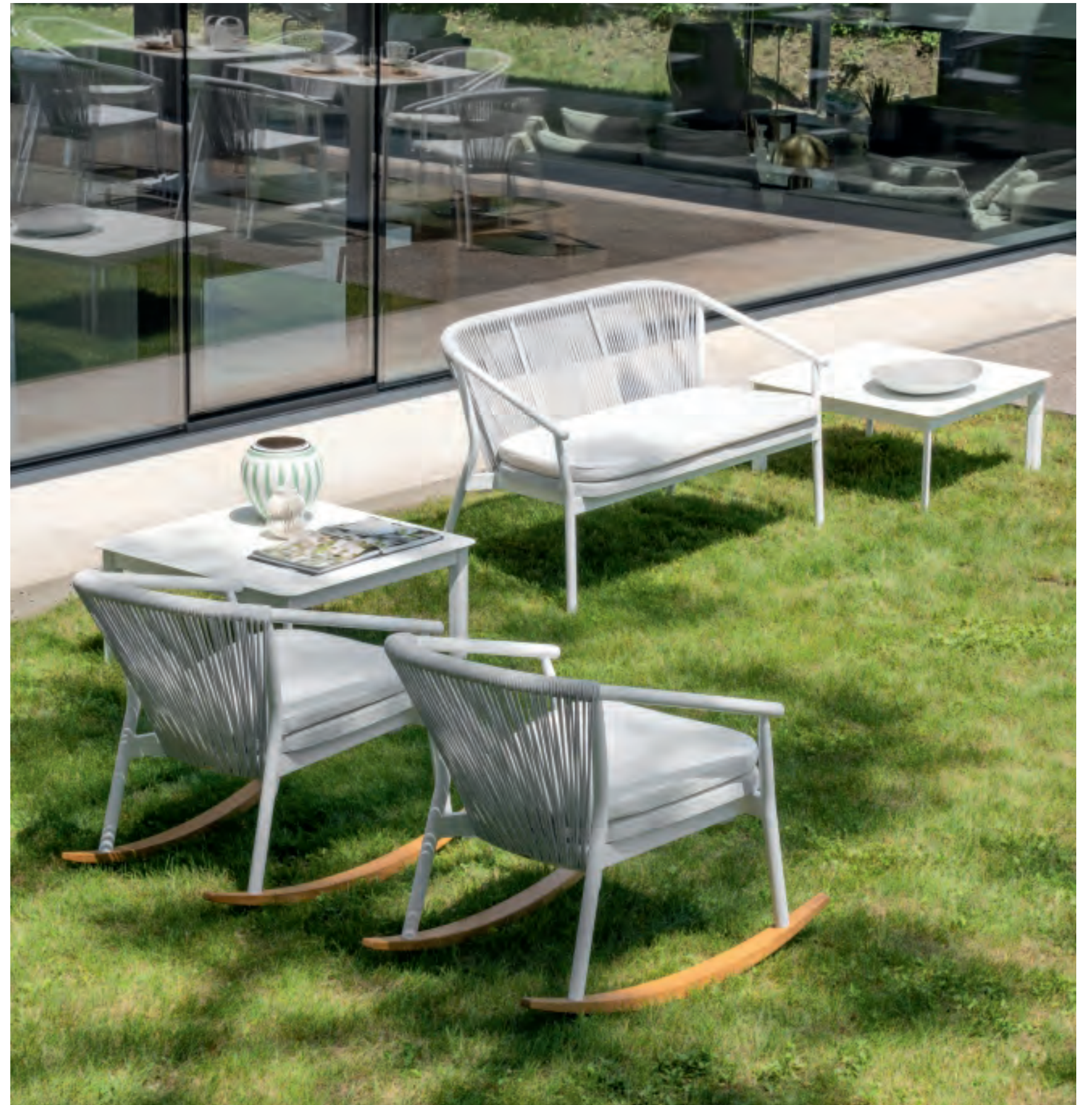



struttura bianco
WHITE STRUCTURE



POLTRONCINA
DINING ARMCHAIR
VAR#TEX BIANCO



POLTRONCINA LOW
LOW DINING ARMCHAIR
VAR#TEX BIANCO



SGABELLO
STOOL
VAR#TEX BIANCO



DONDOLO POLTRONA LOUNGE
ROCKING LOUNGE ARMCHAIR
VAR#TEX BIANCO



POLTRONA LOUNGE
LOUNGE ARMCHAIR
VAR#TEX BIANCO

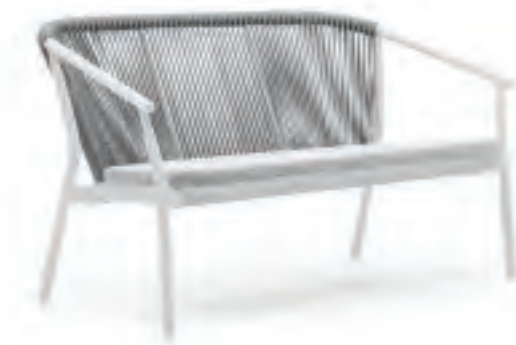

DIVANO 2 POSTI
2 SEATER SOFA
VAR#TEX BIANCO

struttura grigio
GREY STRUCTURE



POLTRONCINA
DINING ARMCHAIR
VAR#TEX CENERE



POLTRONCINA LOW
LOW DINING ARMCHAIR
VAR#TEX CENERE



SGABELLO
STOOL
VAR#TEX CENERE



DONDOLO POLTRONA LOUNGE
ROCKING LOUNGE ARMCHAIR
VAR#TEX CENERE



POLTRONA LOUNGE
LOUNGE ARMCHAIR
VAR#TEX CENERE



DIVANO 2 POSTI
2 SEATER SOFA
VAR#TEX CENERE

plinto

design
Pio e Tito Toso

Base tavolo a colonna centrale realizzata in estruso di alluminio, basamento a terra in pressofusione di alluminio il tutto verniciato a polvere.
Versione zavorrata mediante lastra di acciaio zincato applicata sotto il basamento.

MODELLO REGISTRATO

Central stem table base made of extruded aluminum, ground base in die-cast aluminum, all powder coated. Weighted down using a galvanized steel plate applied under the base.

REGISTERED MODEL

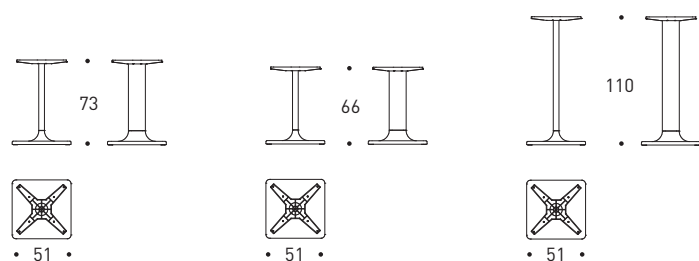

Altezza riferita senza top / Height reported without top

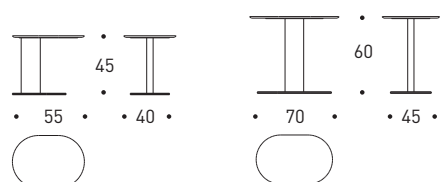

Altezza riferita con top Hpl e ceramica / Height reported with Hpl and ceramic top



500

TAVOLI PLINTO - POLTRONCINE NOSS
PLINTO TABLES - NOSS DINING ARMCHAIRS

501













Plinto nasce dalla ricerca di sintesi fra bellezza e funzionalità. Plinto si ispira alla natura, più precisamente ad un tronco di albero e alle sue radici che lo sostengono: paradigma di stabilità. Plinto è una base compatta che trasmette sicurezza, linearità e pulizia ed è in grado di dialogare con l'architettura che la circonda. La particolare forma della base è ottenuta mediante una pressofusione di alluminio che si raccorda con continuità allo stelo, anch'esso di alluminio, ma estruso. La sezione ovale dello stelo consente di percepire una forma variabile con l'angolo di osservazione del tavolo.



pio e tito toso

TALKS ABOUT PLINTO

Plinto stems from the search for synthesis between beauty and functionality. Plinto is inspired by nature, more precisely by a tree and its supporting roots: a stability paradigm. Plinto is a compact base that inspires safety, linearity and cleanliness and is able to converse with the architecture that surrounds it. The particular shape of the base is obtained by means of an aluminum die-casting, continuously connected to the stem which is also made of aluminum, but extruded. The oval section of the stem allows you to perceive a variable shape according to the viewing angle.

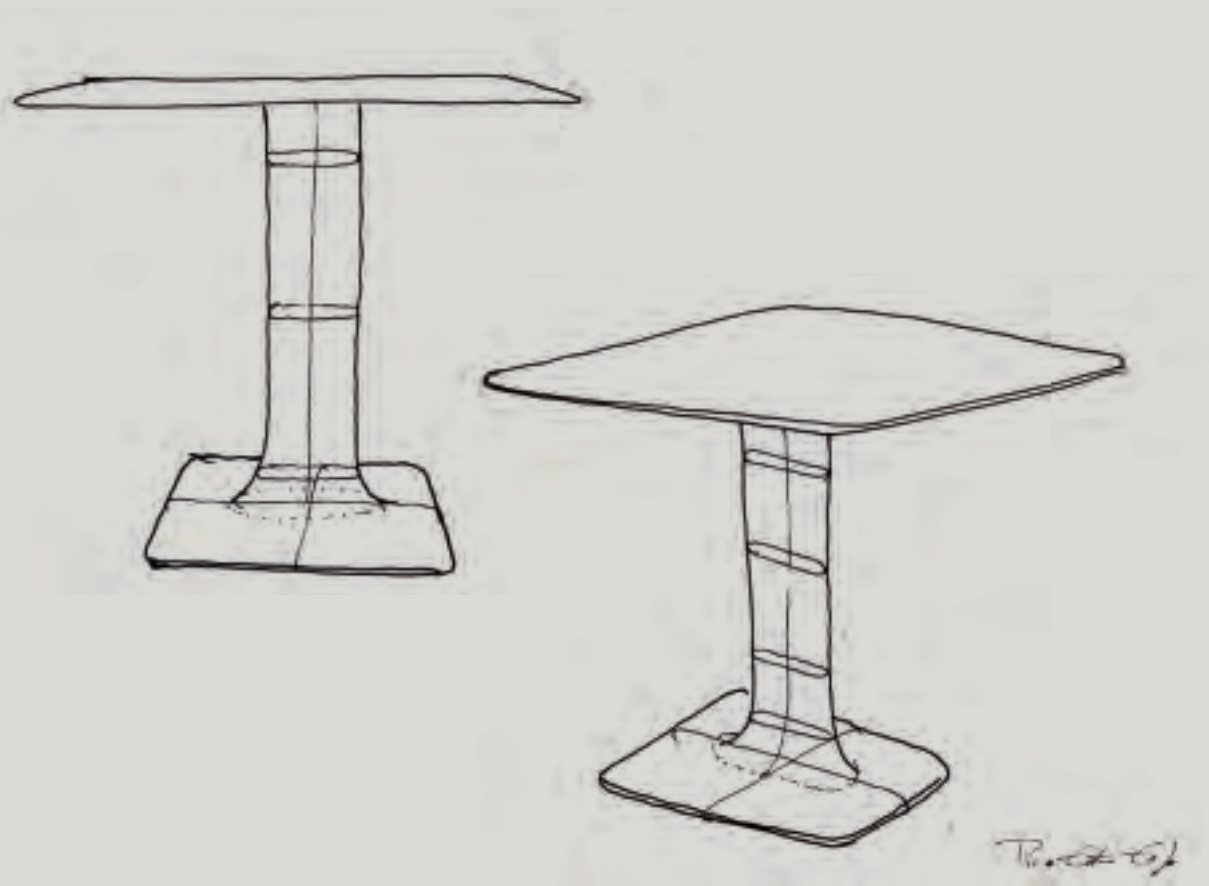

PLINTO

bahia

design
Calvi Brambilla

Collezione con struttura in alluminio verniciato a polveri, sedute e schienali in VAR#TEX (tessuto tecnico in PVC). Modello impilabile.

MODELLO REGISTRATO

Collection in powder coated aluminium frame, seat and backrest in VAR#TEX (PVC based material). Stackable model.

REGISTERED MODEL

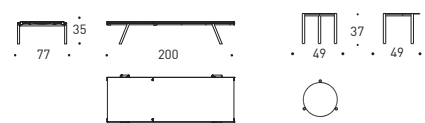



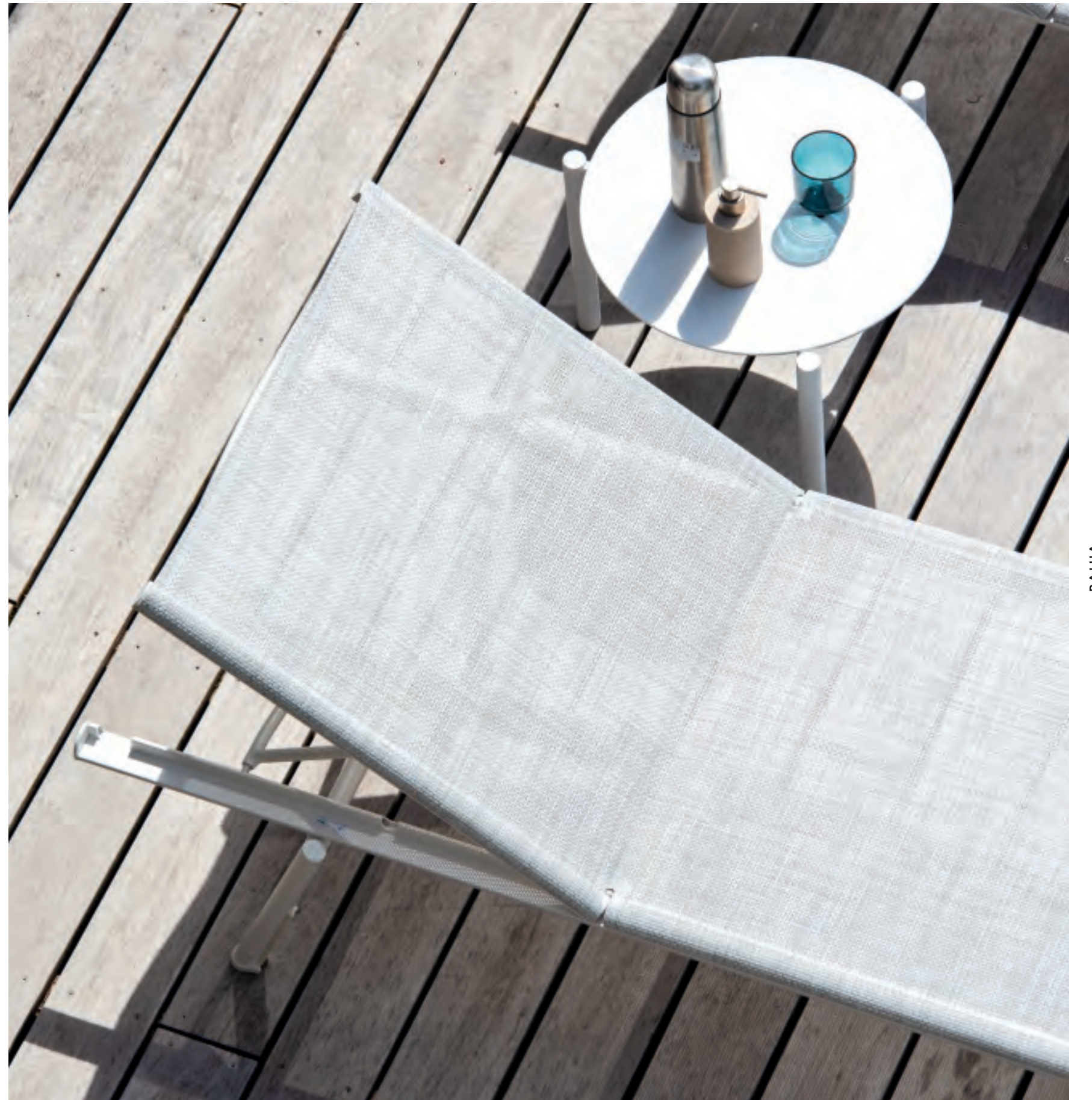
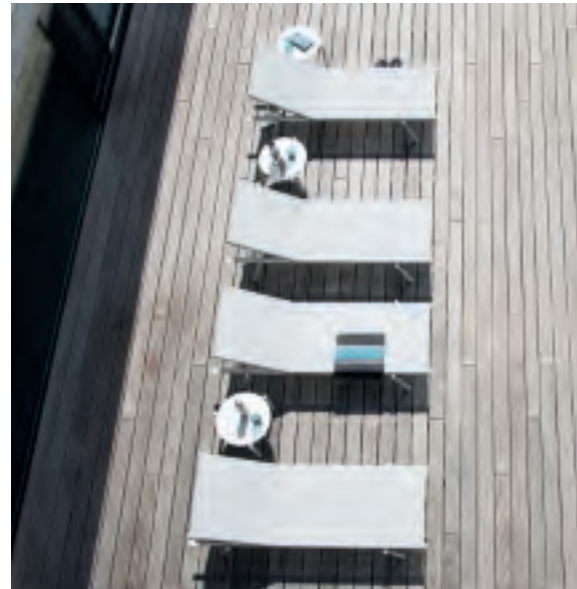









maat design
Philippe Bestenheider

Collezione intrecciata a mano in fibra sintetica
a quattro colori con intelaiatura in alluminio
verniciato a polveri.
Cuscini con imbottitura gomme Dryfeel da esterno.
MODELLO REGISTRATO

*Collection in powder coated aluminium frame
and hand woven man-made fibre in four colours.
Padded cushions in Dryfeel outdoor foam.
REGISTERED MODEL*

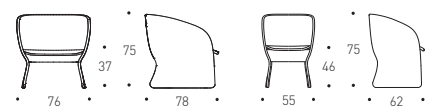







LANDSCAPES '21_'22

MAAT





philippe bestenheider

TALKS ABOUT MAAT

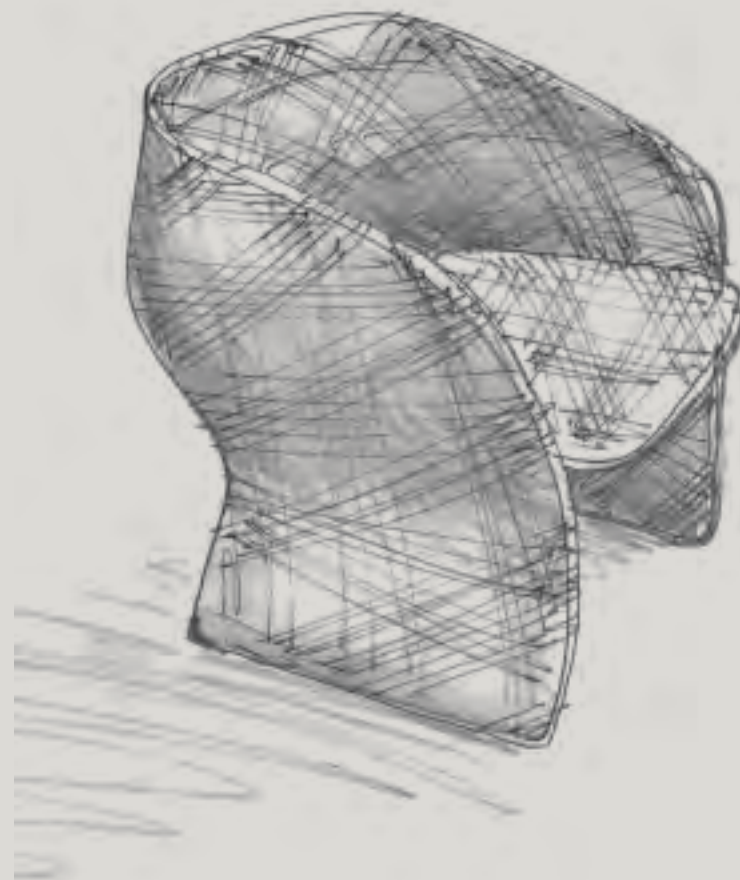

Nel caso di Maat, l'obiettivo finale era dare nuova vita ai mobili per esterno in PVC intrecciato. Innanzitutto la forma tridimensionale della poltrona è frutto di un'accurata progettazione, che ha voluto esaltare la silhouette. Il risultato finale è ottenuto intersecando sinuose prospettive laterali e anteriori. Per sottolineare la forma dell'oggetto è stato scelto un intreccio triangolare a trama larga. L'aspetto arioso della poltrona aumenta la profondità delle superfici e il volume complessivo appare così più leggero.

In the case of Maat, the aim was to give new life to the existing typology of the outdoor furniture in woven PVC. First of all, the three dimensional shapes of the armchair have been thought over, with particular attention to the silhouette. The final shape is obtained by intersecting the sinuous side and front views. In order to underline the shape of the product, a triangular, open-weave pattern was chosen. Its airy appearance adds depth to the surfaces and lets the overall volume seem lighter.



ellisse

design
R&D Varaschin

Collezione tavoli fissi con struttura in alluminio verniciato a polveri con top in Hpl o Ceramica. Disponibili in versione H 74 + top ed in versione Low H 66 + top per essere utilizzati con sedute lounge.

Fixed tables with aluminum, powder coated structure, Hpl or ceramic top. Available in height H74 + top or in the LOW version H66 + top to be used with lounge chairs.

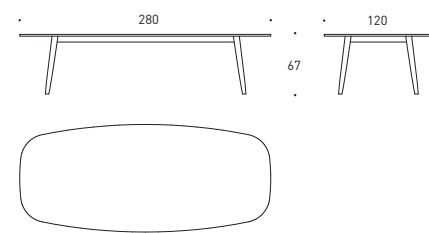
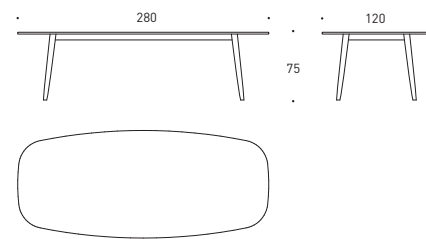
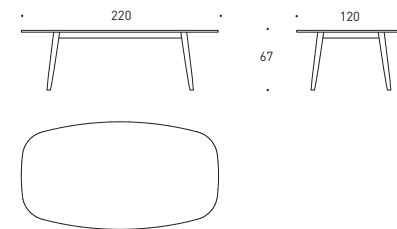
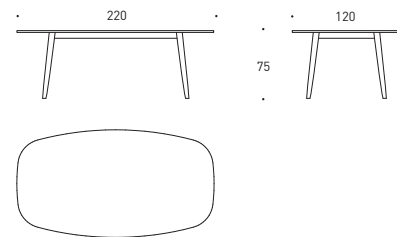

LANDSCAPES '21_'22

ELLISSE

Altezza riferita con top Hpl / Height reported with Hpl top







NEO CAPES 21 '22

ELLISSE





OUTDOOR THERAPY IS
create your
own world

Fin da bambina mi sono espressa con i colori e disegni. La mia mente, la mia immaginazione sono sempre in fermento. Gli occhi rubano dettagli, colori e sensazioni da tutto ciò che mi circonda. Così lascio viaggiare la mente, e mi lascio trasportare dalla mia curiosità e racconto il mio paesaggio.

Since childhood I have expressed myself with colors and drawings. My mind, my imagination are always in turmoil. The eyes steal details, colors and sensations from everything around me. So I let my mind travel, and I let myself be carried away by my curiosity and I narrate my landscape.





kolonaki

design
Calvi Brambilla

Tavolo con basamento in acciaio trafilato piatto
trattato cataforesi per esterno, verniciatura a polveri.
Top disponibile in diverse finiture.

MODELLO REGISTRATO

*Table with flat steel wire base with cataphoresis
treatment for outdoors, powder coated mat finish.
Top available in various materials and finishes.*

REGISTERED MODEL



LANDSCAPES '21_'22

KOLONAKI

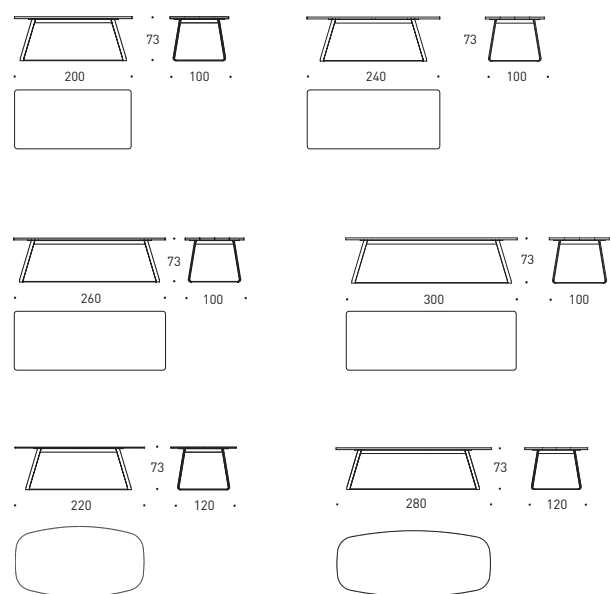

Altezza riferita con top Hpl / Height reported with Hpl top









big in&out

design
Ernesto Lechthaler

Collezione composta da tavolo Big low con piano in Hpl o ceramica disponibile in diverse finiture e 8 poltroncine In&out monotessuto o bitessuto.

Collection composed of table Big Low with Hpl and ceramic tops, available in different finishes, and 8 chairs In&Out available in single-fabric or double-fabric.

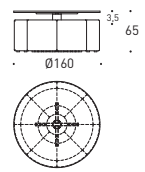







big design
R&D Varaschin

Base tavolo piatta in acciaio con stelo cilindrico e crociera per fissaggio piano.
Ciclo protettivo in cataforesi e finitura a polveri.

Flat steel table base with cylindrical stem and cross support for assembling top.
Protective cycle in cataphoresis and powder coating.

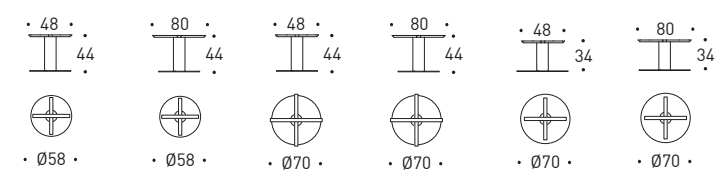
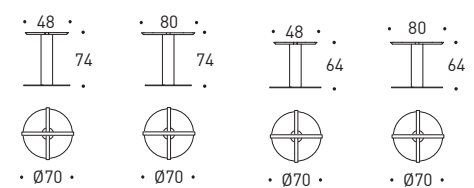
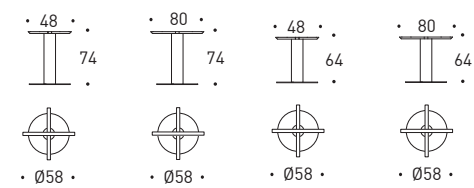
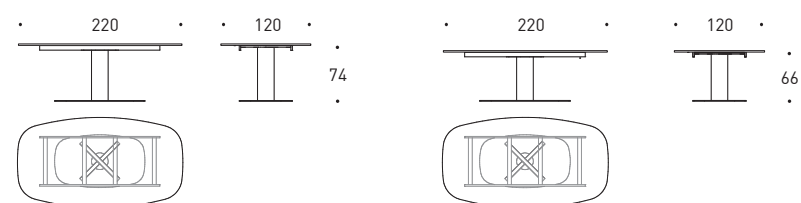

Altezza riferita senza top / Height reported without top













tower

design
Anki Gneib

Collezione di basi per tavoli, realizzata in lamiera di acciaio piegata, verniciata a polveri.

Collection of table bases in powder coated folded powder sheet steel.



LANDSCAPES '21_'22

TOWER

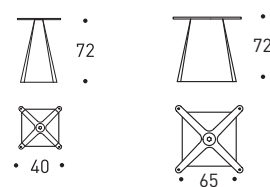

Altezza riferita senza top / Height reported without top







dolmen

design
R&D Varaschin

Tavolo allungabile e fisso con struttura in alluminio verniciato, piano in hpl.

Extendable and fixed table with varnished aluminium structure, hpl top.



LANDSCAPES '21_'22

DOLMEN

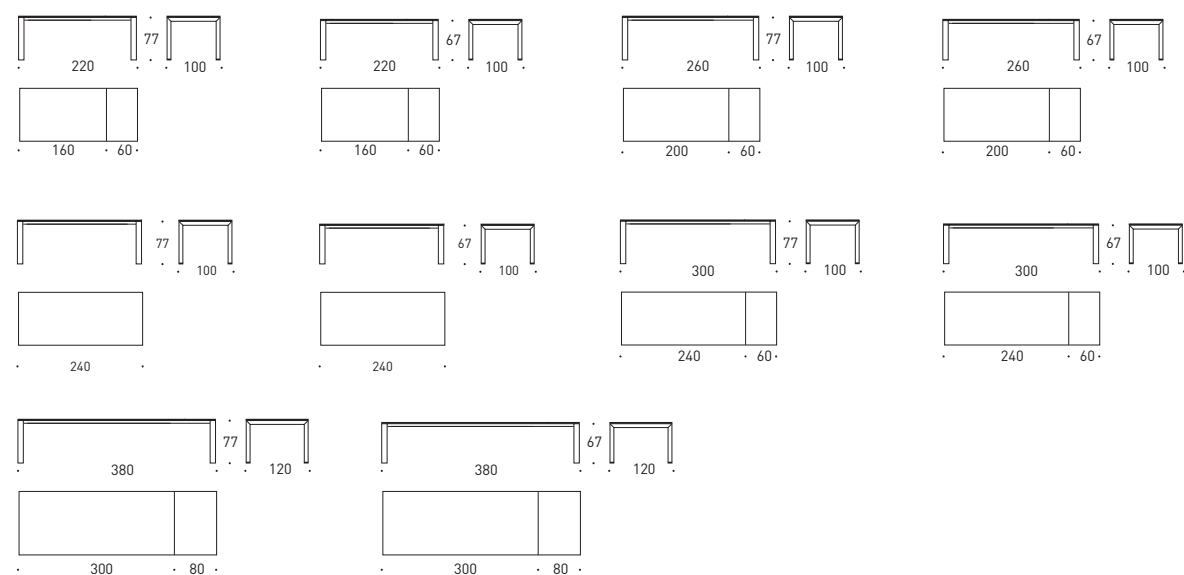

Altezza riferita con top Hpl / Height reported with Hpl top









tight design

R&D Varaschin

Base tavolo piatta in acciaio con stelo a sezione quadra e crociera per fissaggio piano.
Ciclo protettivo in cataforesi e finitura a polveri.
Disponibile con piani in Hpl anche in versione Low (H 66 + top) per essere utilizzati con divani e poltrone lounge.

*Flat steel base with squared stem and cross support for assembling table top.
Cataphoresic and powder coating applied.
Available with Hpl tops also in Low version (H 66 + top) to be used with lounge chairs and armchairs.*

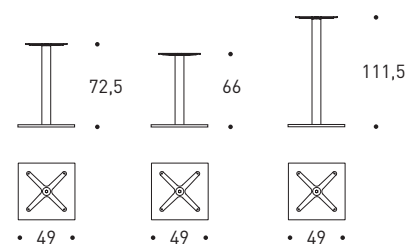

Altezza riferita senza top / Height reported without top





blade

design
R&D Varaschin

Base tavolo in acciaio a 4 razze con stelo a sezione quadra e crociera per fissaggio piano.
Ciclo protettivo in cataforesi e finitura a polveri.
Disponibile anche in versione Low [H 66 + top]
per essere utilizzati con sedute lounge.

*Steel table base with 4 spoke feet and cross support for the top.
Cathaphoresic treatment and powder coating.
Also available in the Low version [H 66 cms + top]
to be used with lounge chairs.*

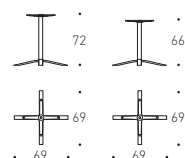

Altezza riferita senza top / Height reported without top



bivacco

design
R&D Varaschin

Gazebo con struttura in alluminio verniciato bianco completo di tende su 3 lati e tettuccio superiore. Materasso di seduta sfoderabile con 2 schienali indipendenti e reclinabili.

Gazebo has a white powder coated aluminum frame with 3 side curtains and sun covering. Seat cushion with removable covers and 2 independent and reclining backrests.

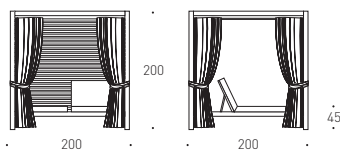





pavilion

design
R&D Varaschin

Pavilion è un gazebo con struttura portante realizzata in alluminio, completa di pavimento a doghe, ciellini frangisole e tende verticali di chiusura.

Pavilion with aluminium supporting structure, slatted floor, sun coverings and side curtains.

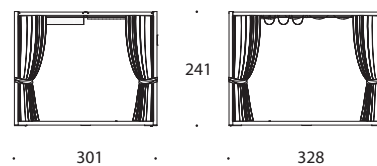



STYLING: JAPES - 21_22

PAVILLION



copacabana

design
R&D Varaschin

Ombrellone a braccio laterale 3,5x3,5 mt o 3x4 mt,
completo di sacco copertura. Base in pietra.

Side arm sunshade 3,5x3,5 mt or 3x4 mt,
with bag cover. Stone base.

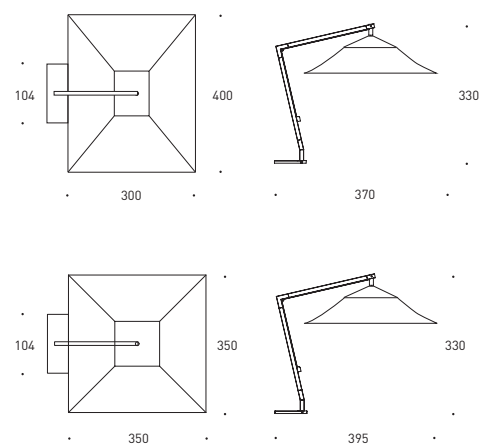

630



OMBRELLONE COPACABANA - COLLEZIONE BARCODE
COPACABANA SUNSHADE - BARCODE COLLECTION

631

amalfi

design
R&D Varaschin

Ombrellone a palo centrale 2,5x2,5 mt.
Base rotonda in cemento.

Central pole sun umbrella 2,5x2,5 mt.
Round cement base.

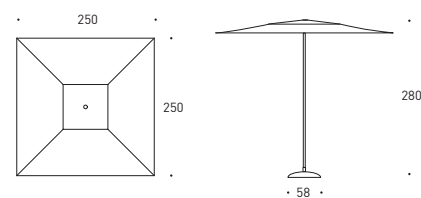

632



OMBRELLONE AMALFI - COLLEZIONE BELT
AMALFI SUNSHADE - BELT COLLECTION

633

carpet

design
R&D Varaschin

Tappeti per esterno realizzati con fibre sintetiche, non-assorbenti e altamente resistenti all'azione degli agenti atmosferici.
100% Polipropilene

*Outdoor carpet in synthetic fibers, non absorbent and highly resistant to bad weather.
100% Polypropelene*

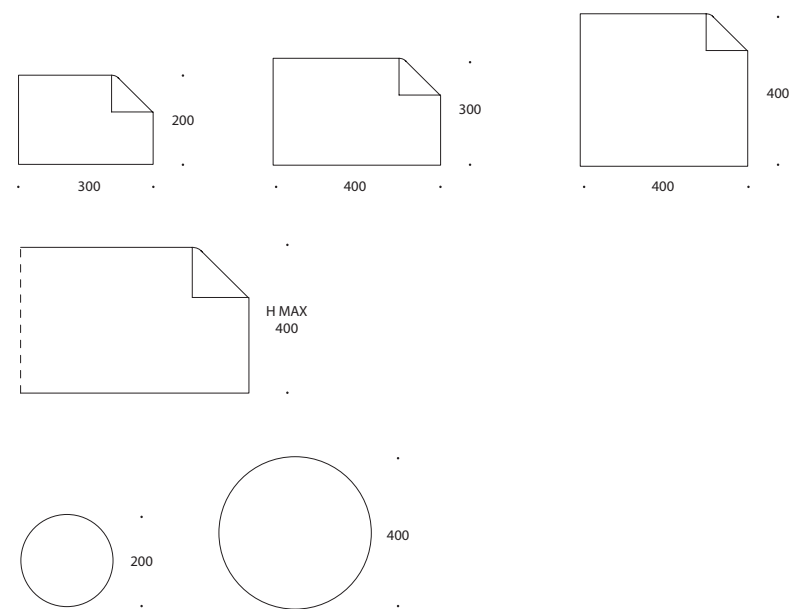

634



CARPET

CARPET - COLLEZIONE TIBIDABO
CARPET - TIBIDABO COLLECTION

635

GRIGIO/GREY



TAUPE/TAUPE



BRONZO/BRONZE



trama

design
R&D Varaschin

Coperta per esterno con lavorazione maglia rasata.
Composizione 100% Olyna.

Outdoor knitted blanket made of 100% Olyna.



BEIGE/BIANCO
BEIGE-WHITE



TORTORA
TAUPE



OTTANIO/BRONZO
TEAL/BRONZE



GRIGIO/GREY

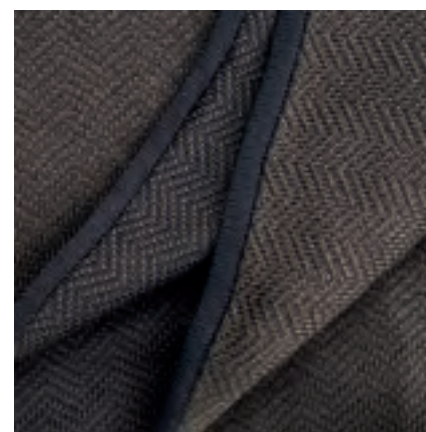

BRONZO/TABACCO
BRONZE/TOBACCO

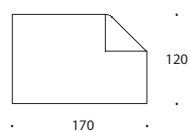

638

LANDSCAPES '21_'22



COPERTA TRAMA - POUF BELT - TAVOLINO PLINTO
TRAMA BLANKET - BELT POUF - PLINTO COFFEE TABLE

639

COVER

design
R&D Varaschin

Le cover dei nostri modelli, adatte alla protezione dei prodotti in ambienti outdoor, sono confezionate su misura alla composizione divano, ordinata dal cliente. Vengono realizzate contemporaneamente al confezionamento del divano stesso, con tessuto poliestere al 100%, 180 grammi a metro quadro, colore grigio chiaro, spalmato un lato con resina acrilica, con trattamento teflon antimacchia ed olio-idrorepellente, studiato e realizzato appositamente per la massima resistenza al passaggio diretto dell'acqua, secondo le indicazioni della normativa tecnica, UNI EN 20811, permeabilità all'acqua, colonna d'acqua maggiore di 1000mm.

The coverings of our collections are suitable for the protection against atmospheric agents. They are custom-made pieces according to the sofa composition, which is chosen by the customer. Sofa and covering are produced at the same time and are composed 100% of polyester fabrics, with a density of 180 gram per square meter. The polyester fabric is lightgrey and has one side of acrylic resin and Teflon coating, which makes the fabric water-and oil proof. These coverings have been designed and created to resist the direct water passage [according to the technical standard UNI EN 20811, the water permeability and the water column test higher than 1000 mm].



640



COVER

641

low dining collection

NOT ONLY PRODUCT, BUT CONCEPT.

Pochi centimetri fanno la differenza nello stare a tavola.
L'altezza ridotta dei tavoli abbinati
alle sedute lounge e poltroncine low,
sviluppa una nuova modalità di relazione,
unicamente outdoor.

*Few centimeters make the difference when dining.
The reduced table height combined
with lounge seats and low armchairs,
develops a new relationship mode
uniquely outdoor.*



LANDSCAPES '21_'22

low tables h67

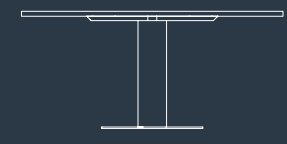

BIG LOW

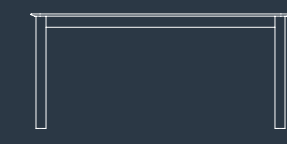

SYSTEM LOW



EMMA LOW

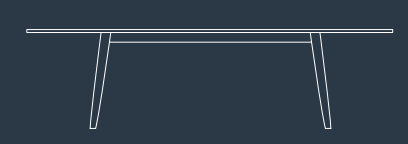

ELLISSE LOW

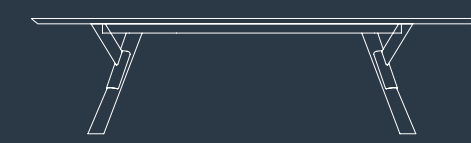

LINK LOW

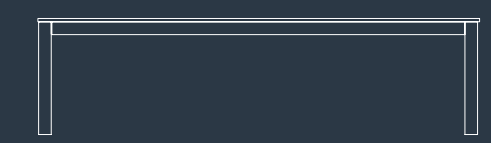

VICTOR LOW

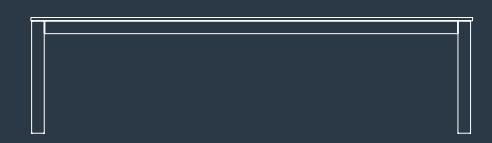

DOLMEN LOW



SUMMER SET LOW



PLINTO LOW



TIGHT LOW



BLADE LOW

LOW DINING



LANDSCAPES 21-22

low armchairs h40

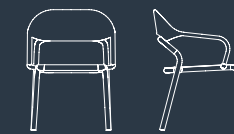

NOSS LOW



SMART LOW



VICTOR LOW

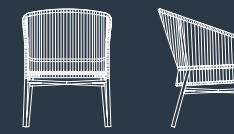

CRICKET LOW

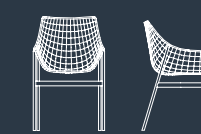

SUMMER SET LOW



EMMA CROSS LOW

LOW DINING



LANDSCAPES '21-'22

lounge armchairs h40

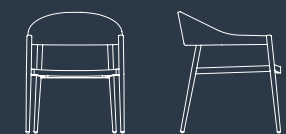

CLEVER



SMART

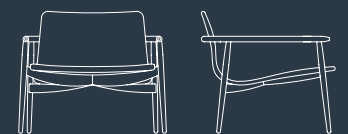

LAPIS

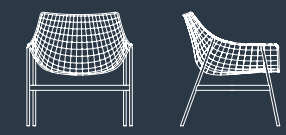

SUMMER SET



CRICKET



MAAT

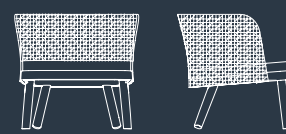

EMMA

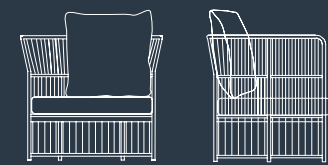

TIBIDABO

LOW DINING

colorful outdoor

PRODUCTS ARE OUR CANVAS

La natura è una tela di colore straordinaria.
Sono i colori gli abitanti dello spazio, le linee
viaggiano intorno ad esso e definiscono le forme.
Varaschin Outdoor Therapy è filosofia che nasce
dal rispetto di codici immutabili che vestono
ogni giorno il nostro prodotto di felicità.

*Nature is an extraordinary canvas of colors.
Colors are the inhabitants of space,
lines travel around it and define shapes.
Varaschin Outdoor Therapy is a philosophy
born from the respect of immutable codes
that dress every day our product with happiness.*

MOODBOARD

LANDSCAPES '21_'22

autumn vibes

LANDSCAPES '21_'22



CERAMIC / CERAMICA
grey porphyry / porfido grigio

ABACO
C478 - bronzo

GEMMA
D172 - corallo

BATYLINE
grey

STRIPES
B553 - bordeaux

ALUMINIUM / ALLUMINIO
moka / dark brown

PIPER
B093 - liquirizia

MOODBOARD

deep forest

LANDSCAPES 21 - '22

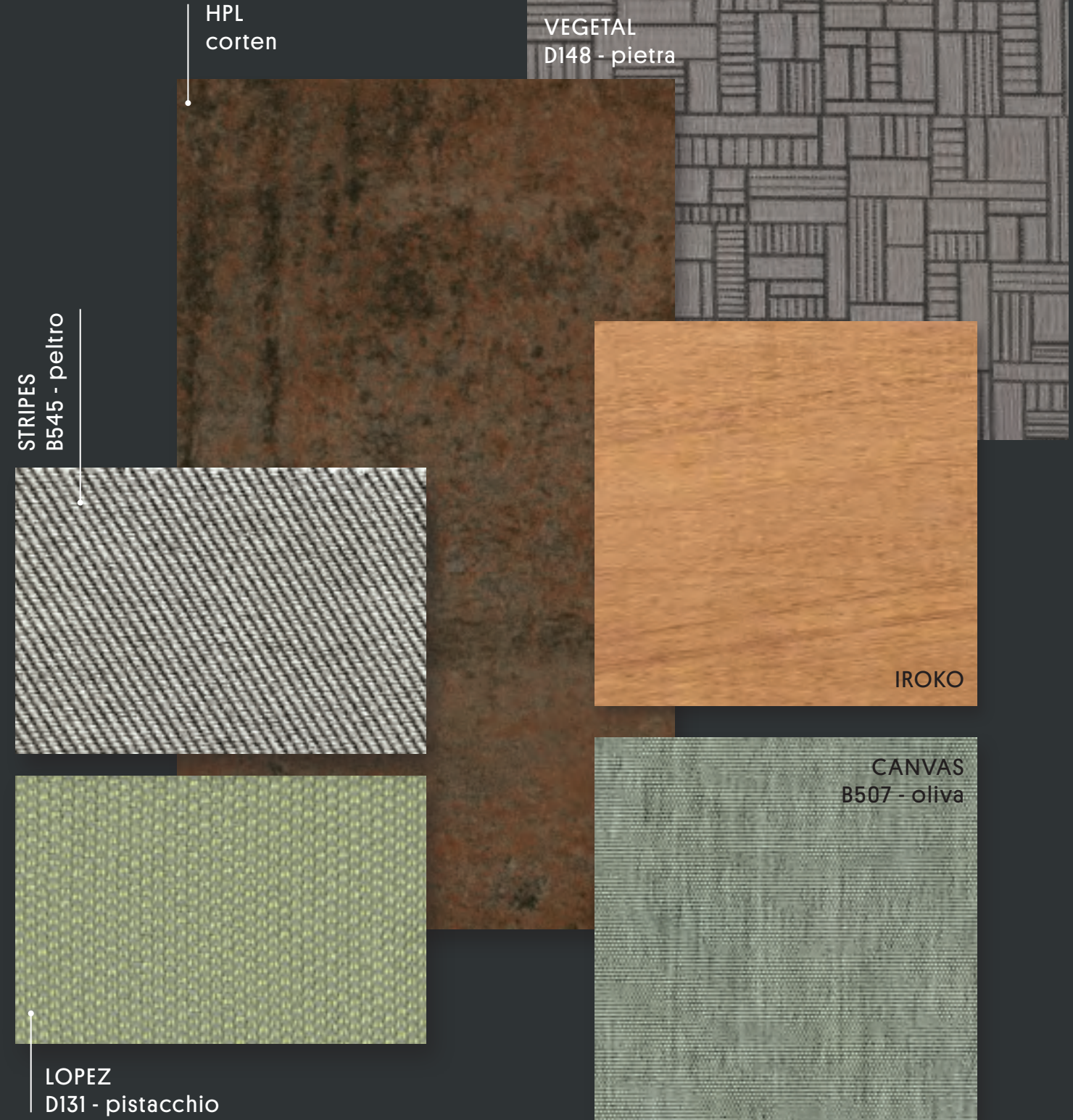

MOODBOARD

peaceful desert

LANDSCAPES '21_'22

VEGETAL
D145 - zinco

HPL
corten

CANVAS
B510 - orange

PANAMA
B139 - mais

CANVAS
B508 - citron

MARINE
C100 - beige

ALUMINIUM / ALLUMINIO
bronze / bronzo

MOODBOARD

high mountain

LANDSCAPES '21_'22



ALUMINIUM / ALLUMINIO
grey / grigio

PIPER
B091 - polvere

CERAMIC / CERAMICA
lime white / bianco calce

TEAK

LOPEZ
D129 - palude

STRIPES
B544 - argento

OSCAR
B20 - bianco

MOODBOARD

nordic lakeshore

LANDSCAPE 22

VEGETAL
D143 - artico

HPL
bedonia

TEXTURE
perla

PIPER
B090 - marmo

LOPEZ
D128 - ghiaccio

CANVAS
B504 - acquerello

ALUMINIUM / ALLUMINIO
silk grey / grigio seta

MOODBOARD

wild waterfall

LANDSCAPES '21 '22



JAZZ
E482 - seta

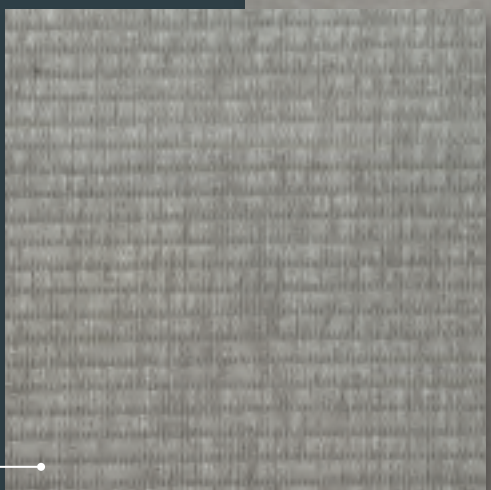

PANAMA
B1383 - righe carbone



ALUMINIUM / ALLUMINIO
Black / nero



HPL
cement / cemento



TEXTURE
gabardina

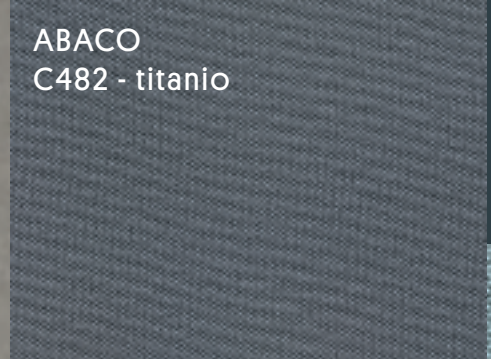

ABACO
C482 - titanio

CANVAS
B504 - acquerello

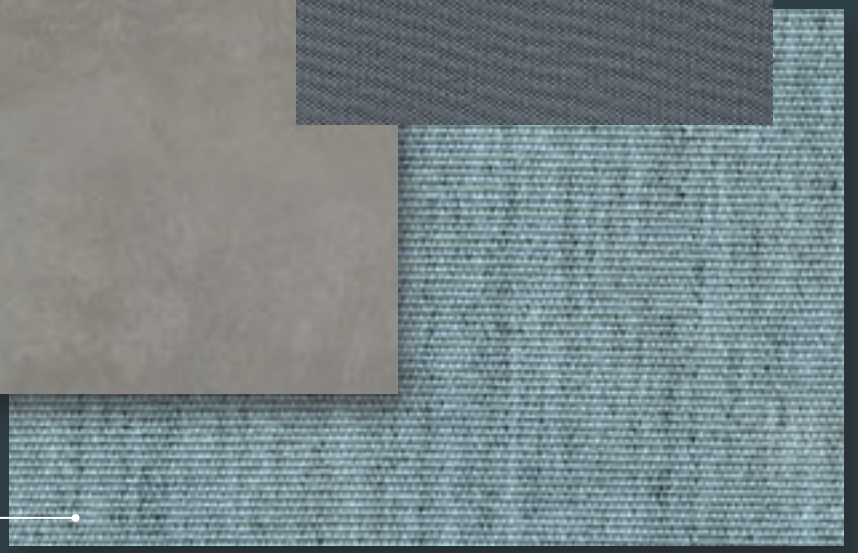

MOODBOARD

endless ocean

LANDSCAPES '21_'22

VAR#TEX
acquerello

VAR#TEX
white / bianco

JUNGLE
B127 - celeste

ALUMINIUM / ALLUMINIO
silk grey / grigio seta

ABACO
C480 - oceano

POP
E458 - turchese

VELLUTO
D182 - turchese

HPL
silk grey / grigio seta

Panama
B1394 - grigio chiaro

MOODBOARD

tropical jungle

LANDSCAPES 21_22

TELINA
grey brown

MARINE
C102 - lime

CERAMIC / CERAMICA
grey porphyry / porfido grigio

LOPEZ
D131 - pistacchio

PANAMA
B135 - green

VOGUE
E102 - monstera

VEGETAL
D146 - oliva

ALUMINIUM / ALLUMINIO
moka / dark brown

MOODBOARD

dark seaside

LANDSCAPES '21



CERAMIC / CERAMICA
dark stone / grigio scuro

VOGUE
E104 - piquet

ALUMINIUM / ALLUMINIO
black / nero

ABACO
C485 - nero

ABACO
C481 - blu

MARINE
C110 - fumo

LOPEZ
D129 - palude

STRIPES
B544 - argento

MOODBOARD

artic cliff

LANDSCAPES '21_'22

HPL
silk grey / grigio seta

VAR#TEX
white / bianco

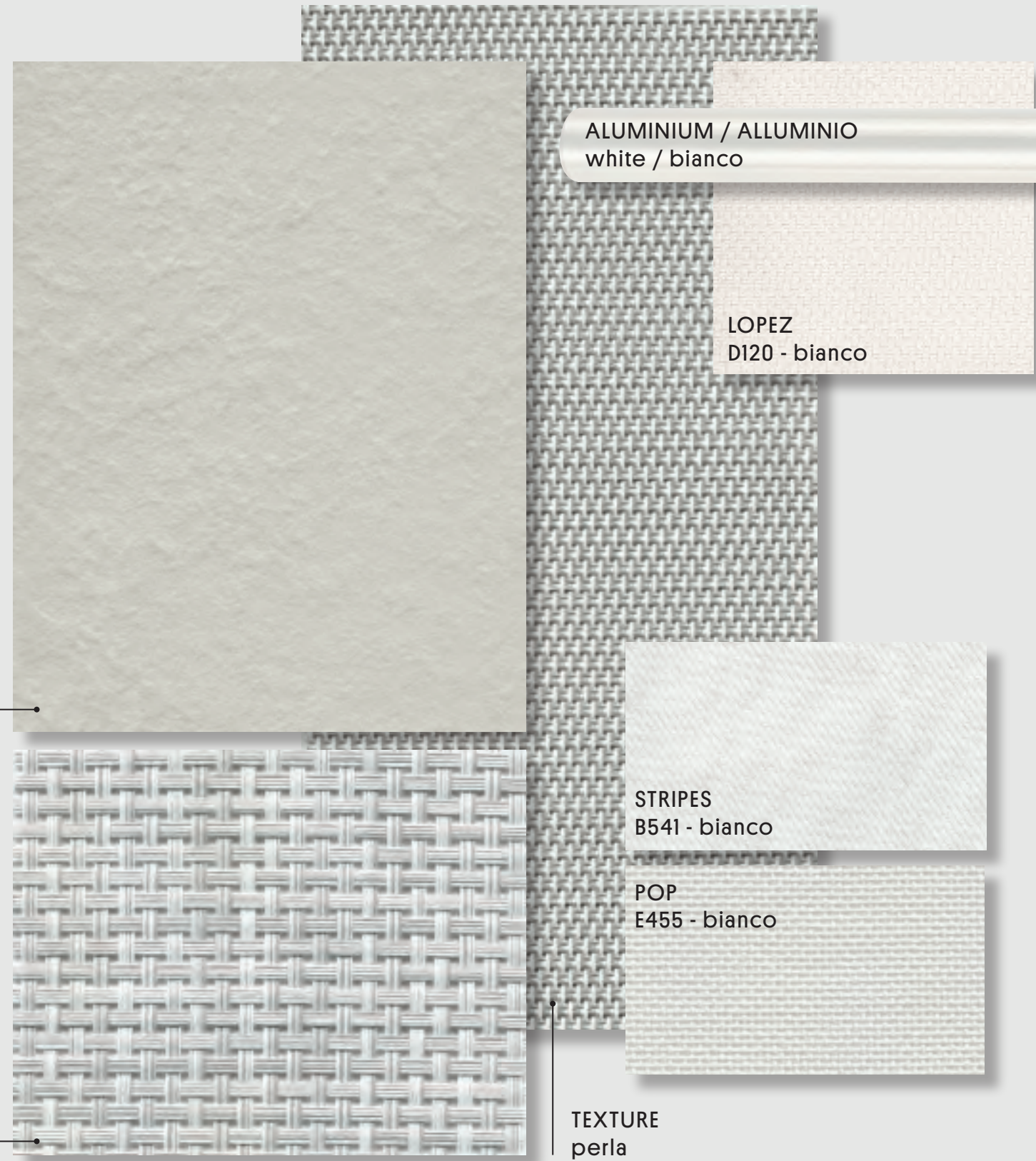

ALUMINIUM / ALLUMINIO
white / bianco

LOPEZ
D120 - bianco

STRIPES
B541 - bianco

POP
E455 - bianco

TEXTURE
perla

MOODBOARD

AD Daniele Lo Scalzo Moscheri
STYLING Cora Vohwinkel / Irene Arescaldino / Jennifer Graf
PHOTO Gian Paolo Serna / Riccardo Stocco [assistente]
DRONE PHOTO Gian Paolo Serna / Claudio Zavagno
FOTOLITO lucegroup.it
STAMPA sincromia.it cod.200743

Thanks LinenMe

Stampa Ottobre 2020



Varaschin S.p.A
via Cervano 20 / 31029
Vittorio Veneto (TV) Italia

T 39 0438 56 45
F 39 0438 564 666

varaschin@varaschin.it
varaschin.it